

DIAGRAMMES

CLAUDE HENRY
CHRISTIAN LAIR
Atlas des Figures

Diagrammes, tome 59-60 (2008), p. 1-36

http://www.numdam.org/item?id=DIA_2008__59-60__A2_0

© Université Paris 7, UER math., 2008, tous droits réservés.

L'accès aux archives de la revue « Diagrammes » implique l'accord avec les conditions générales d'utilisation (<http://www.numdam.org/conditions>). Toute utilisation commerciale ou impression systématique est constitutive d'une infraction pénale. Toute copie ou impression de ce fichier doit contenir la présente mention de copyright.

NUMDAM

Article numérisé dans le cadre du programme
Numérisation de documents anciens mathématiques
<http://www.numdam.org/>

**SUR
CERTAINES SOUS-CATEGORIES NON PLEINES
DES
CATEGORIES DE MODELES**

*Fascicule 2 :
Atlas des Figures*

Claude Henry

(maxchen@free.fr)

et

Christian Lair

(lairchrist@aol.com)

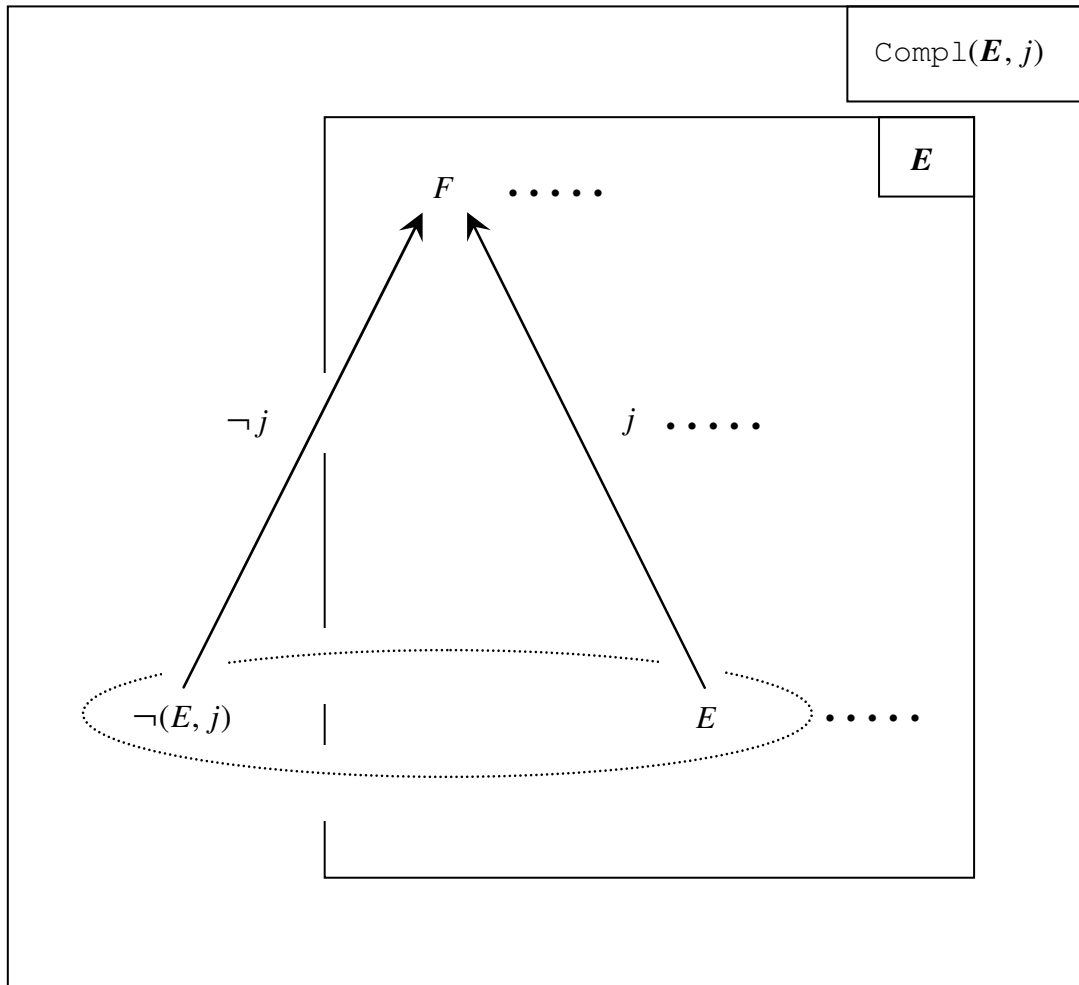
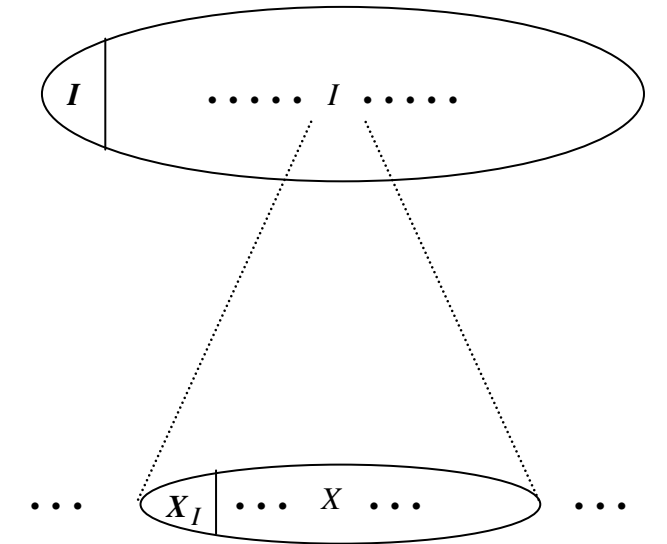

Figure 1



..... R_I



$P_{I,X}$

..... $P_{I,X}$

---> $\in \text{Fl}(M)$

Figure 2

M, M'

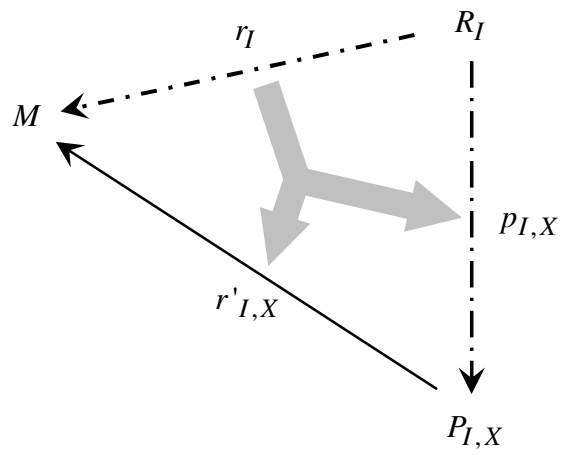

$\dashrightarrow \in \text{Fl}(M)$
 $\longrightarrow \in \text{Fl}(M')$

Résol. 1

$\forall M \in \text{Ob}(M') = \text{Ob}(M) \quad \forall I \in I \quad \forall r_I : R_I \rightarrow M \in \text{Fl}(M)$
 $\exists X \in X_I \quad \exists r'_{I,X} : P_{I,X} \rightarrow M \in \text{Fl}(M')$
 $r'_{I,X} \cdot p_{I,X} = r_I$

Figure 3

M, M'

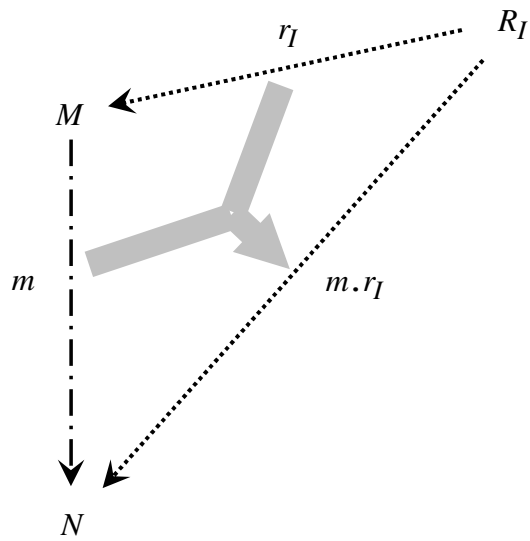

$\dashrightarrow \in \text{Fl}(M)$

$\cdots\rightarrow \notin \text{Fl}(M')$

Résol. 2

$$\forall M \in \text{Ob}(\mathbf{M}) \quad \forall N \in \text{Ob}(\mathbf{M}) \quad \forall m : M \rightarrow N \in \text{Fl}(\mathbf{M})$$

$$\forall I \in \mathbf{I} \quad \forall r_I : R_I \rightarrow M \in \text{Fl}(\mathbf{M})$$

$$r_I : R_I \rightarrow M \notin \text{Fl}(\mathbf{M}') \Rightarrow m.r_I \notin \text{Fl}(\mathbf{M}')$$

Figure 4

M, M'

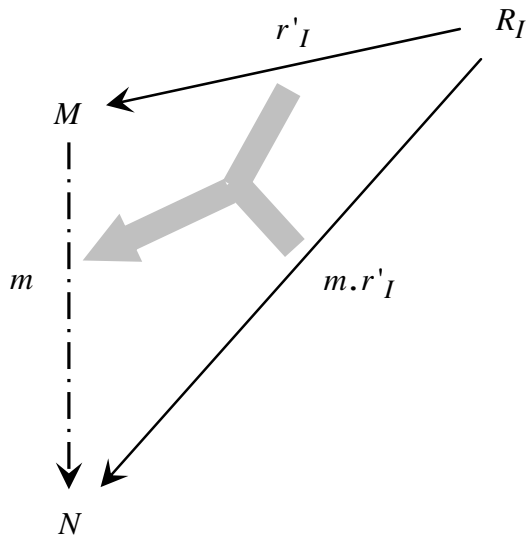

$\text{---} \rightarrow \in \text{Fl}(M)$

$\text{---} \rightarrow \in \text{Fl}(M')$

Résol. 3

$$\begin{aligned} & \forall M \in \text{Ob}(M) \quad \forall N \in \text{Ob}(M) \quad \forall m : M \rightarrow N \in \text{Fl}(M) \\ & [\forall I \in I \quad \forall r'_I : R_I \rightarrow M \in \text{Fl}(M') \quad m.r'_I : R_I \rightarrow N \in \text{Fl}(M')] \\ & \quad \quad \quad \Rightarrow \\ & [m : M \rightarrow N \in \text{Fl}(M')] \end{aligned}$$

Figure 5

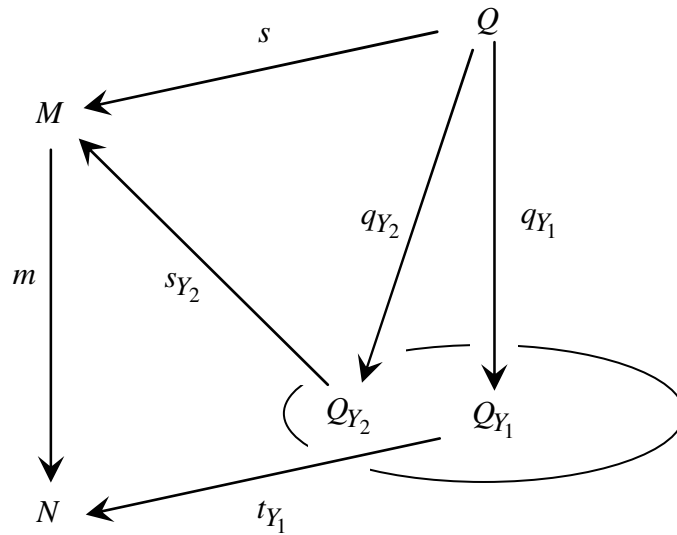
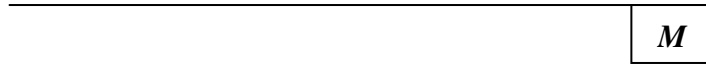
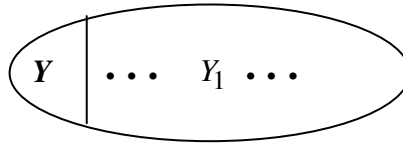

Equil. 1

$$\forall M \in \text{Ob}(\mathbf{M}) \quad \forall N \in \text{Ob}(\mathbf{M}) \quad \forall m : M \rightarrow N \in \text{Fl}(\mathbf{M})$$

$$\forall q = (q_Y : Q \rightarrow Q_Y \in \text{Fl}(\mathbf{M})) \in \mathbf{q} \quad \forall s : Q \rightarrow M \in \text{Fl}(\mathbf{M})$$

$$(\exists Y_1 \in Y \quad \exists t_{Y_1} : Q_{Y_1} \rightarrow N \in \text{Fl}(\mathbf{M}) \quad m \cdot s = t_{Y_1} \cdot q_{Y_1})$$

$$\Rightarrow$$

$$(\exists Y_2 \in Y \quad \exists s_{Y_2} : Q_{Y_2} \rightarrow M \in \text{Fl}(\mathbf{M}) \quad s = s_{Y_2} \cdot q_{Y_2})$$

Figure 6

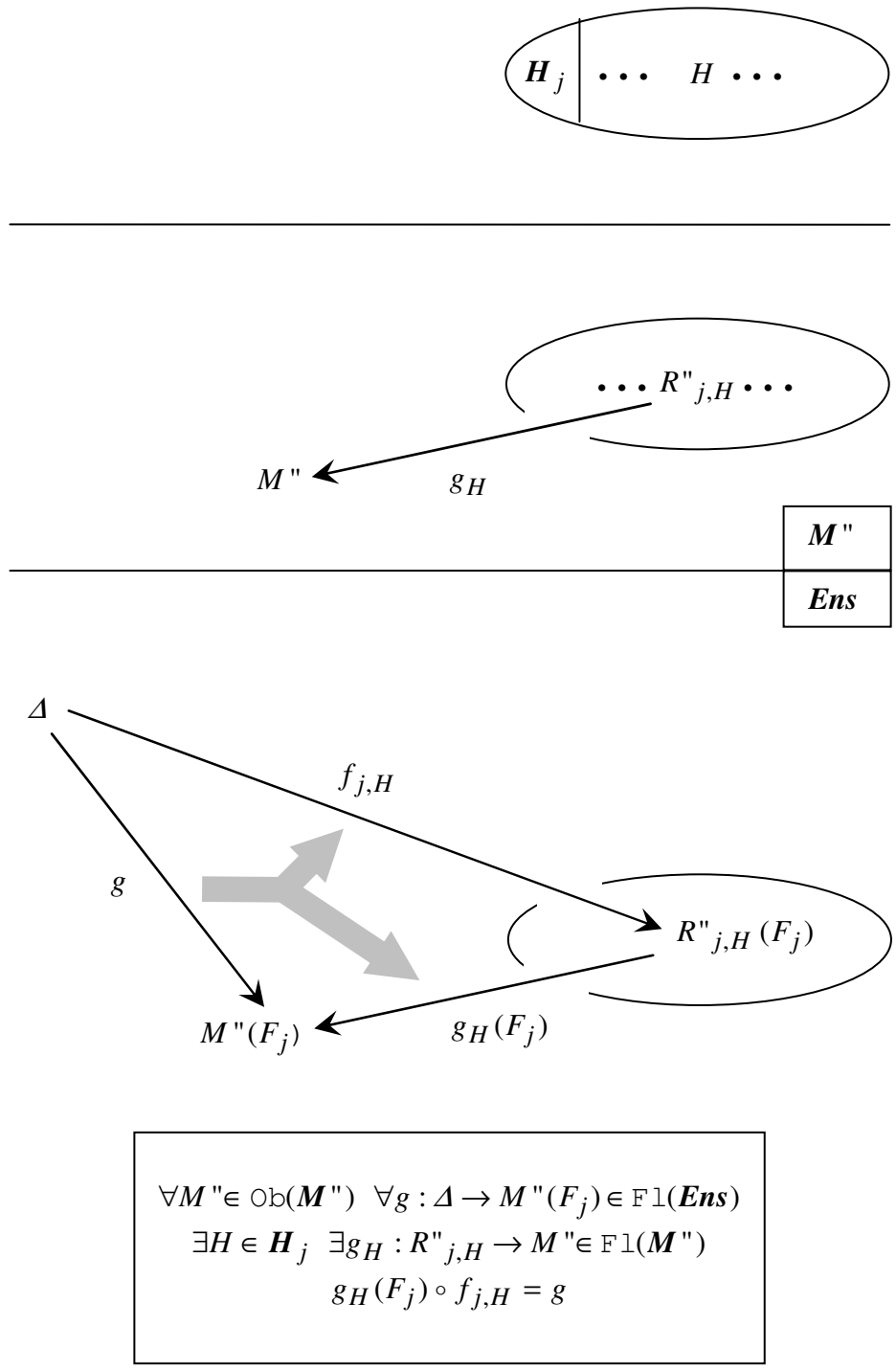

Figure 7

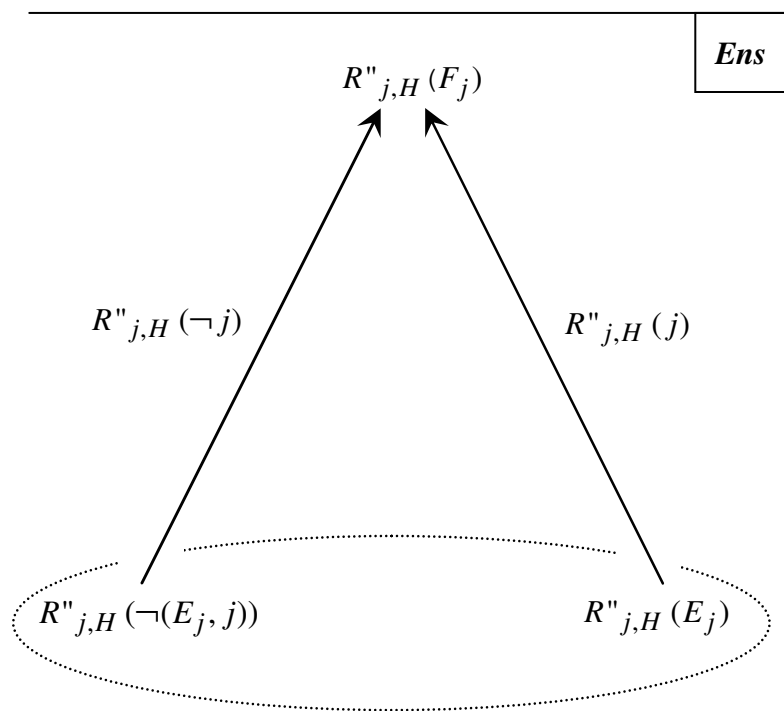

Figure 8

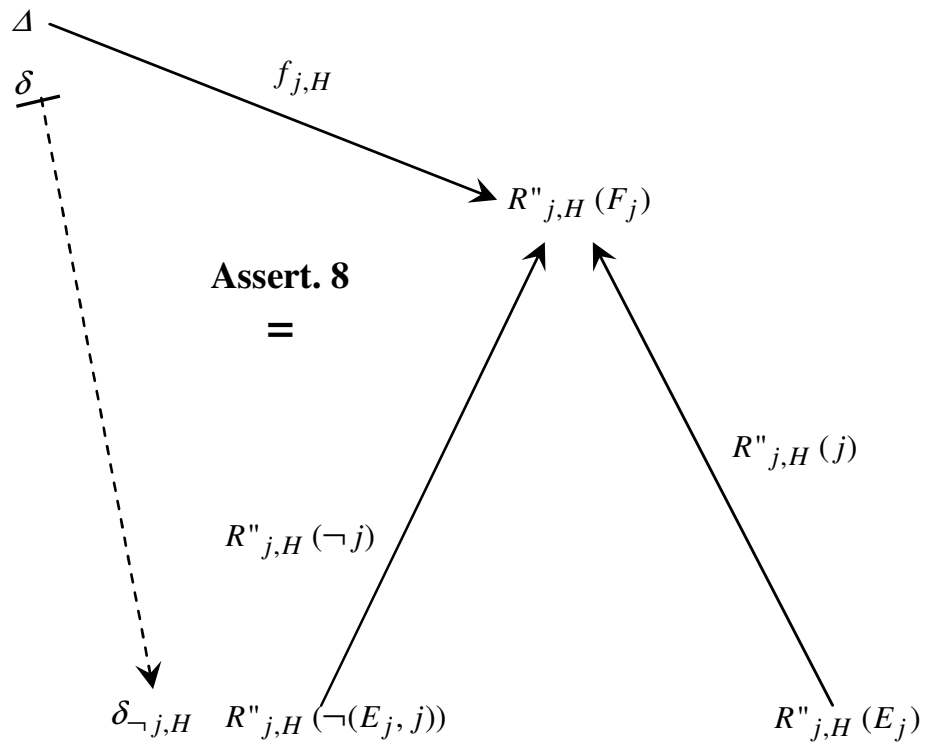
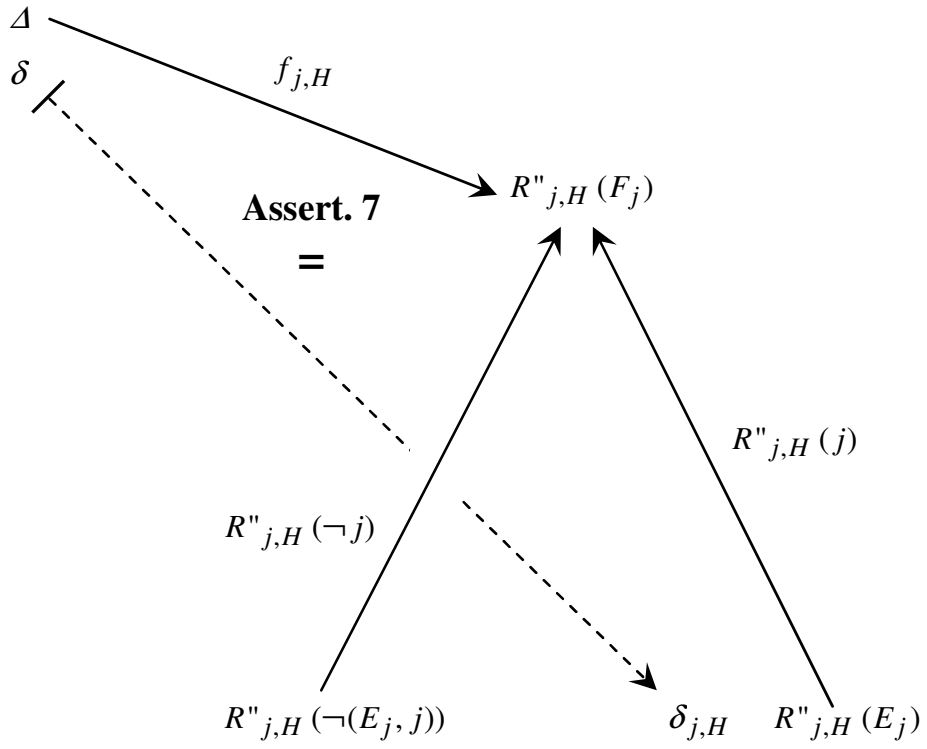
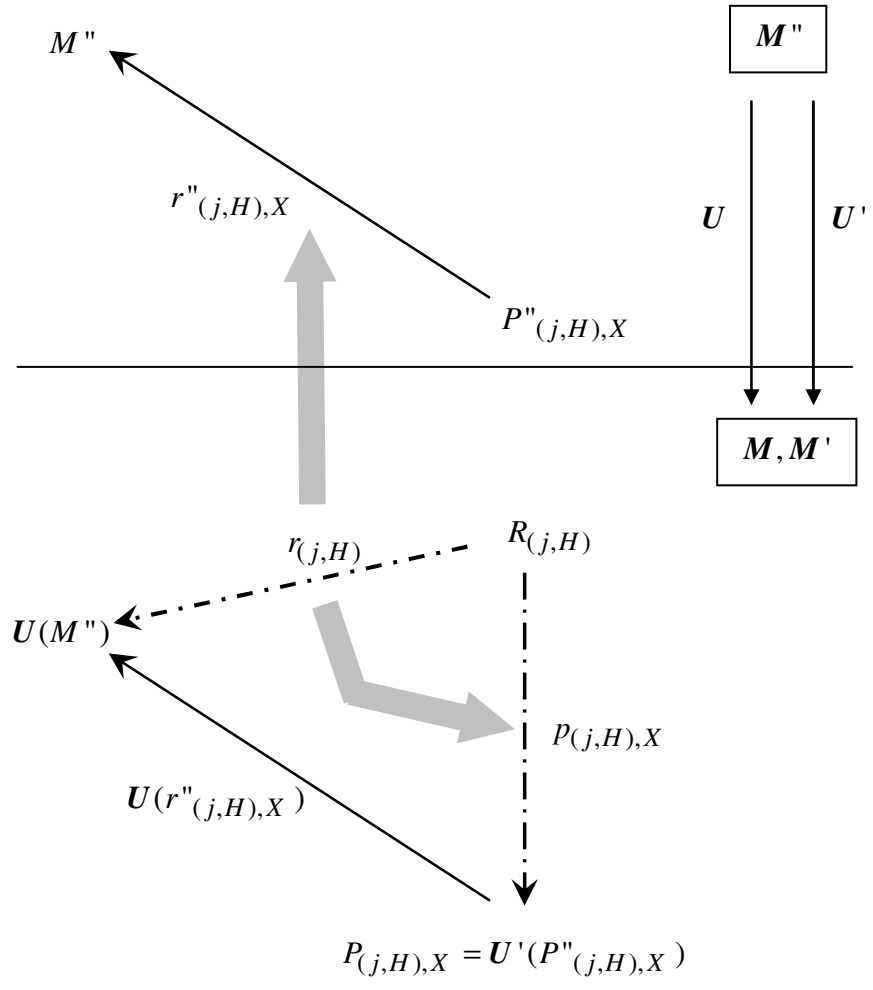

Figure 9



$\dashrightarrow \in \text{Fl}(M)$
 $\longrightarrow \in \text{Fl}(M'') \cup \text{Fl}(M')$

$$\begin{aligned}
 &\forall M'' \in \text{Ob}(M'') \quad \forall (j, H) \in I \quad \forall r_{(j,H)} : R_{(j,H)} \rightarrow U(M'') \in \text{Fl}(M) \\
 &\quad \exists X \in X_{(j,H)} \quad \exists r''_{(j,H),X} : P''_{(j,H),X} \rightarrow M'' \in \text{Fl}(M'') \\
 &\quad \quad U(r''_{(j,H),X}) \cdot P_{(j,H),X} = r_{(j,H)}
 \end{aligned}$$

Figure 10

\mathbf{M}, \mathbf{M}'

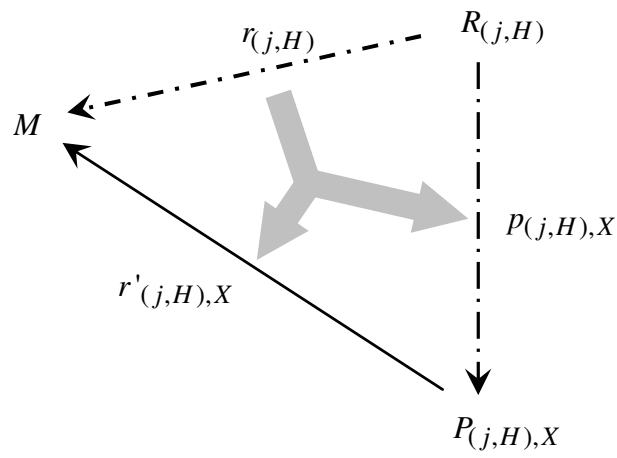

$\dashrightarrow \in \mathbf{Fl}(\mathbf{M})$
 $\longrightarrow \in \mathbf{Fl}(\mathbf{M}')$

$$\begin{aligned}
 &\forall M \in \text{Ob}(\mathbf{M}') = \text{Ob}(\mathbf{M}) \quad \forall (j, H) \in \mathbf{I} \quad \forall r(j, H) : R(j, H) \rightarrow M \in \mathbf{Fl}(\mathbf{M}) \\
 &\quad \exists X \in \mathbf{X}_{(j, H)} \quad \exists r'(j, H), X : P(j, H), X \rightarrow M \in \mathbf{Fl}(\mathbf{M}') \\
 &\quad \quad r'(j, H), X \cdot P(j, H), X = r(j, H)
 \end{aligned}$$

Figure 11

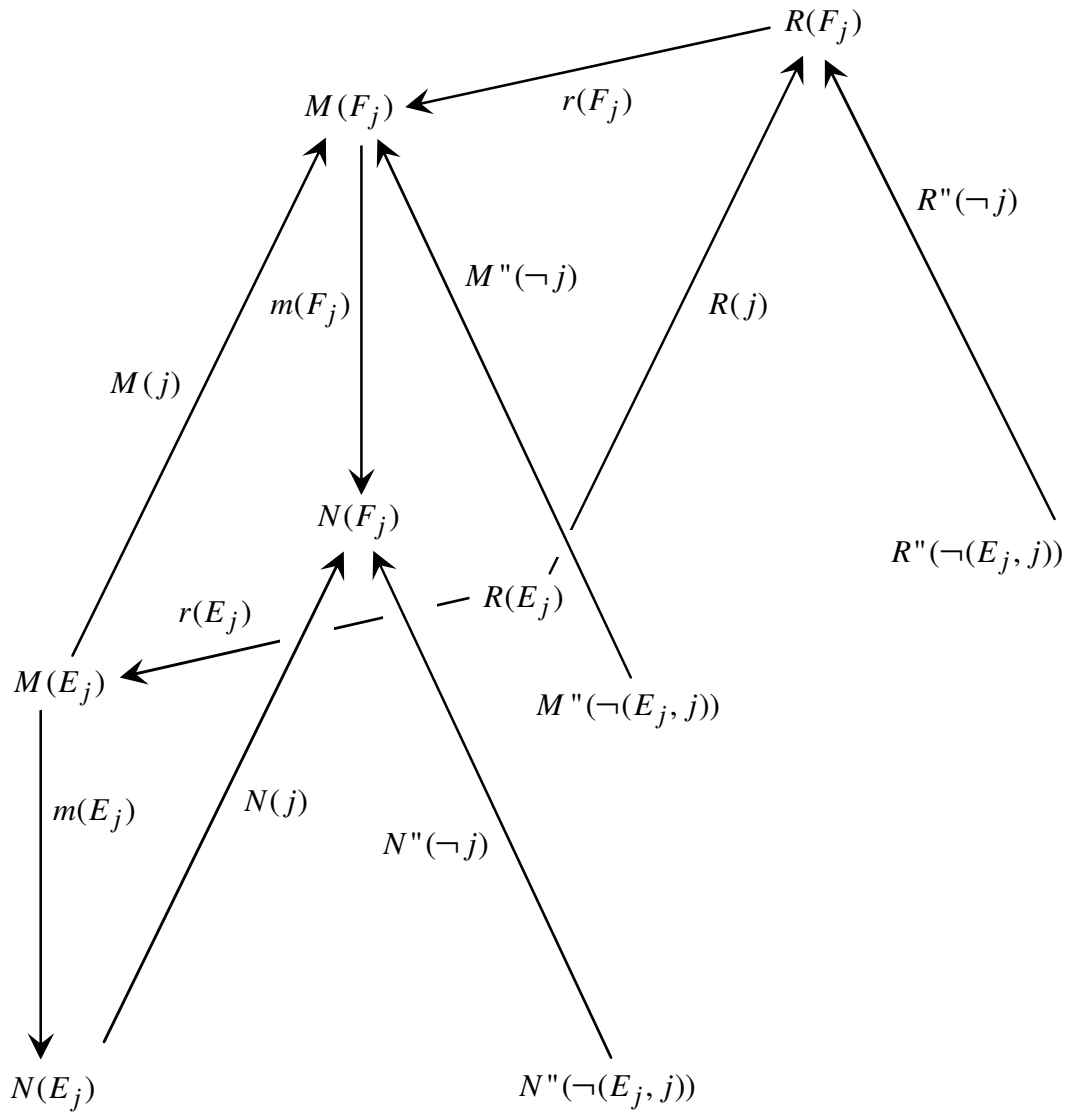

Figure 12

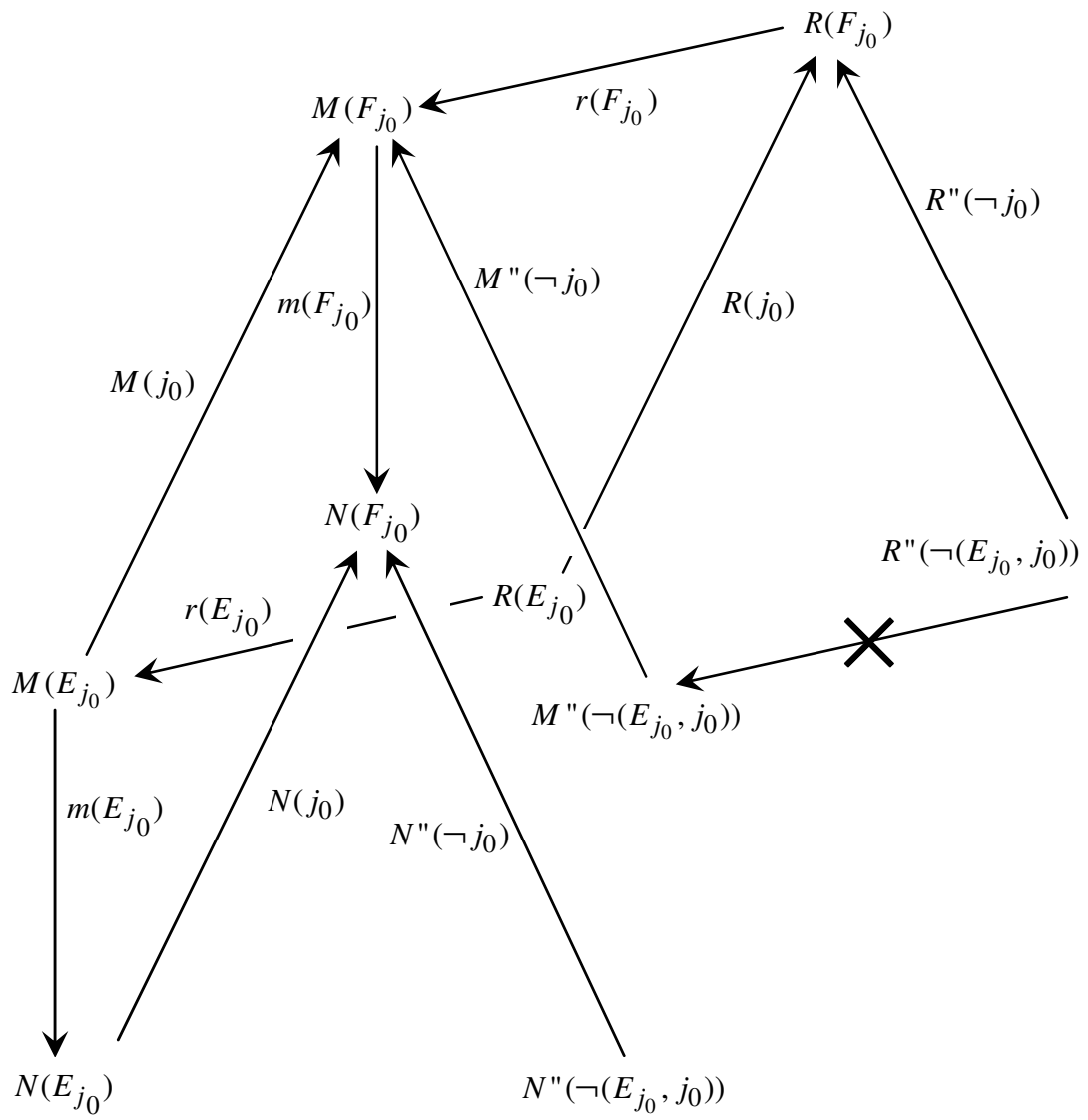

Figure 13

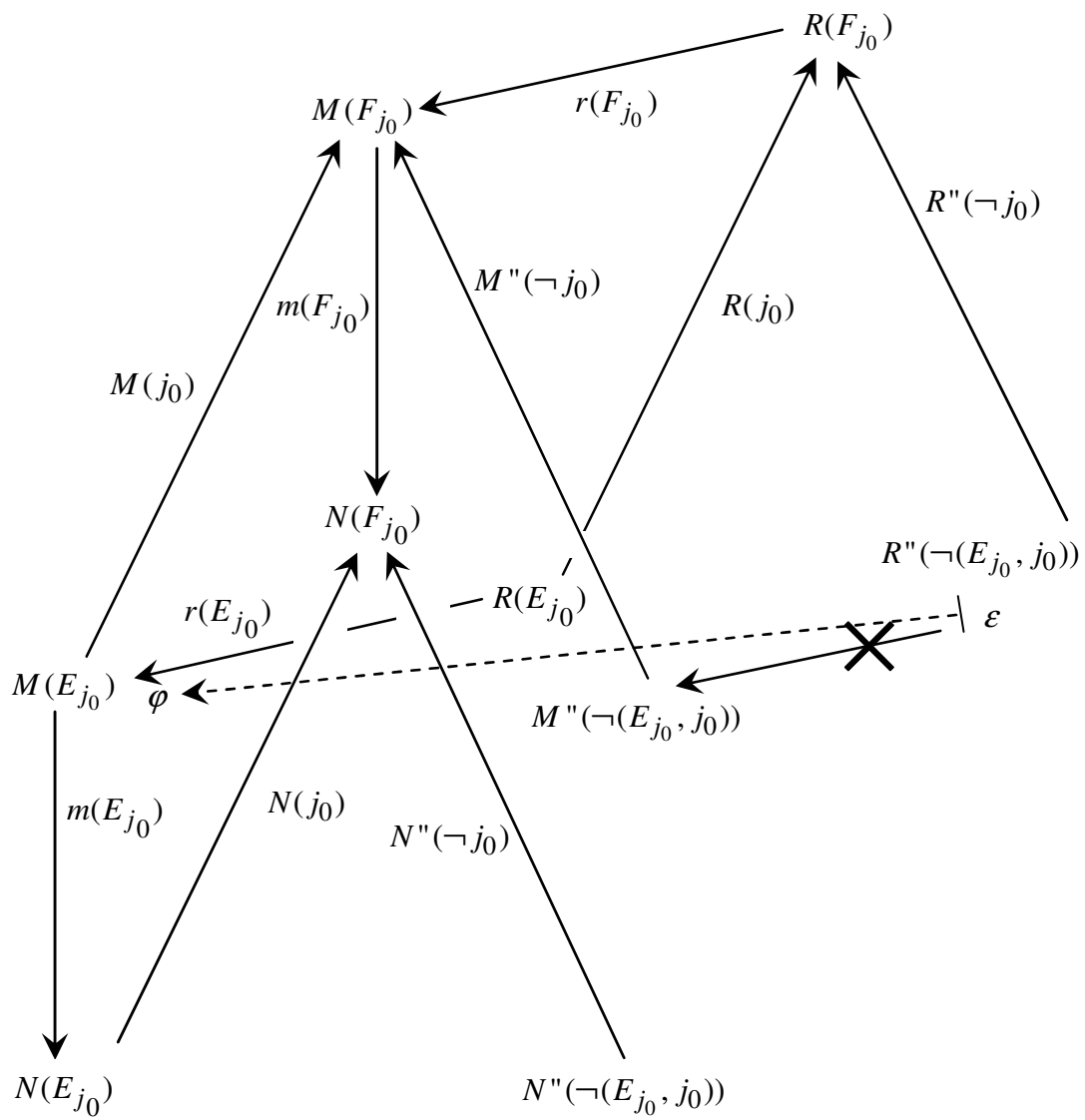

Figure 14

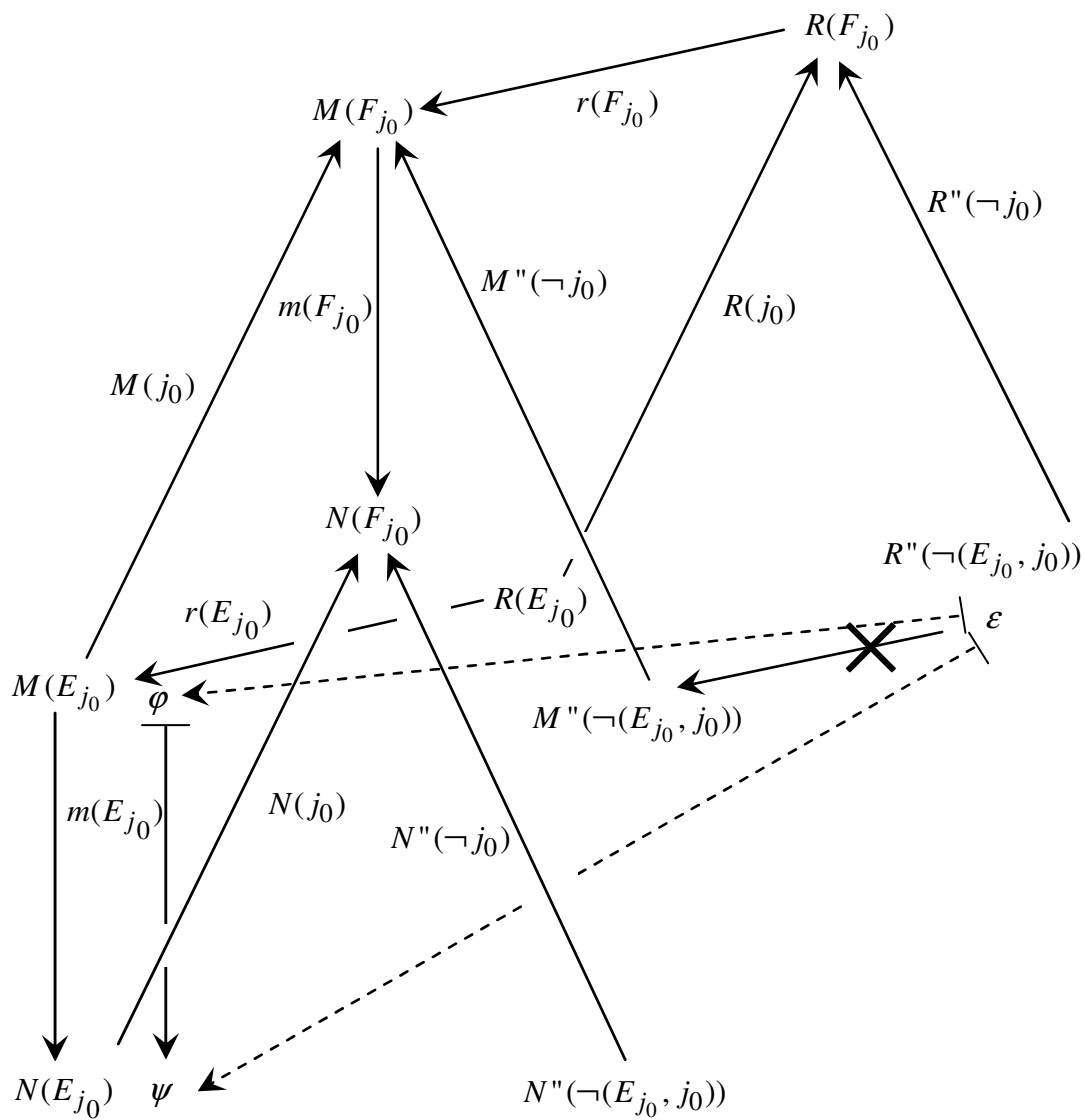

Figure 15

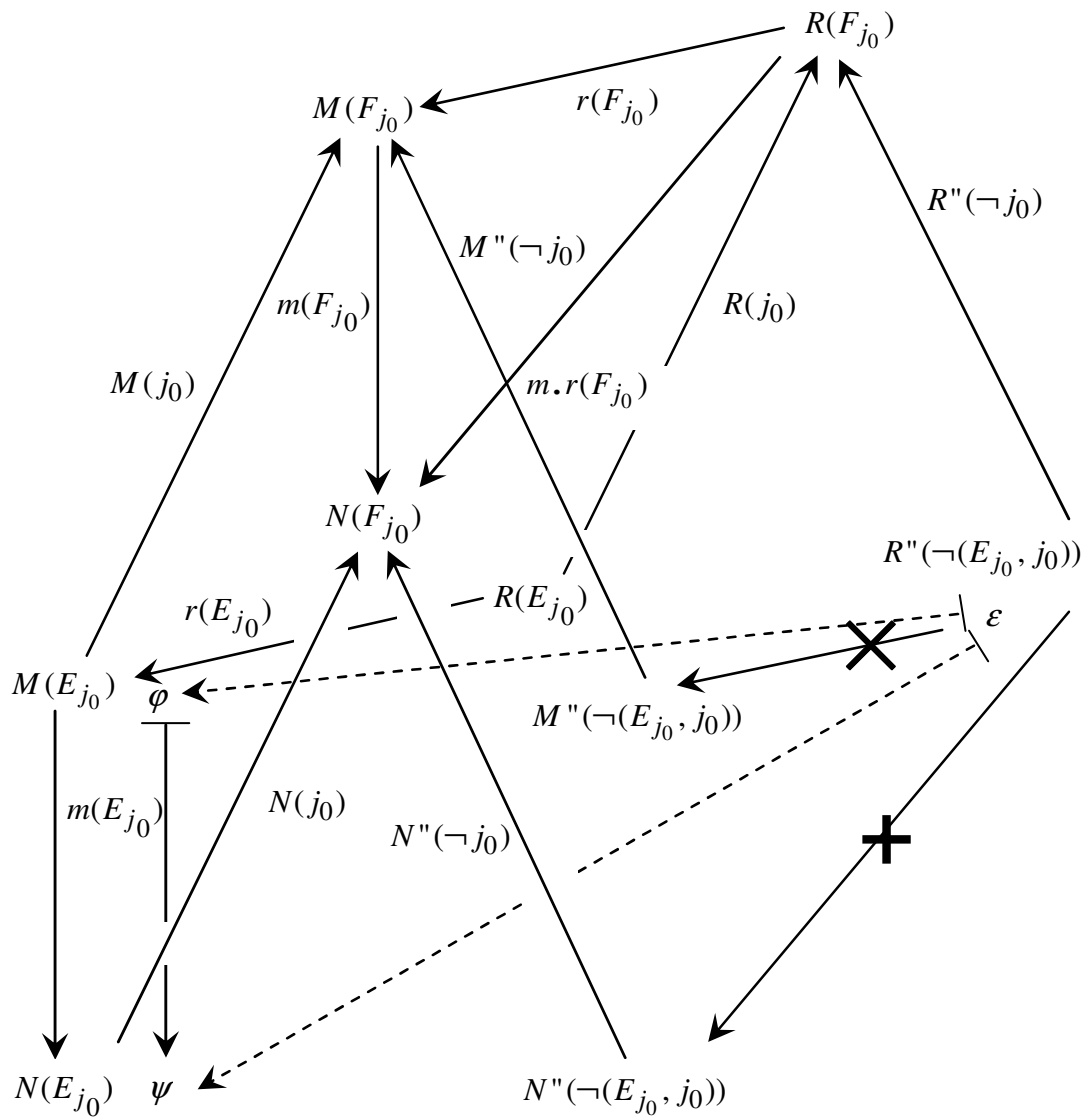

Figure 16

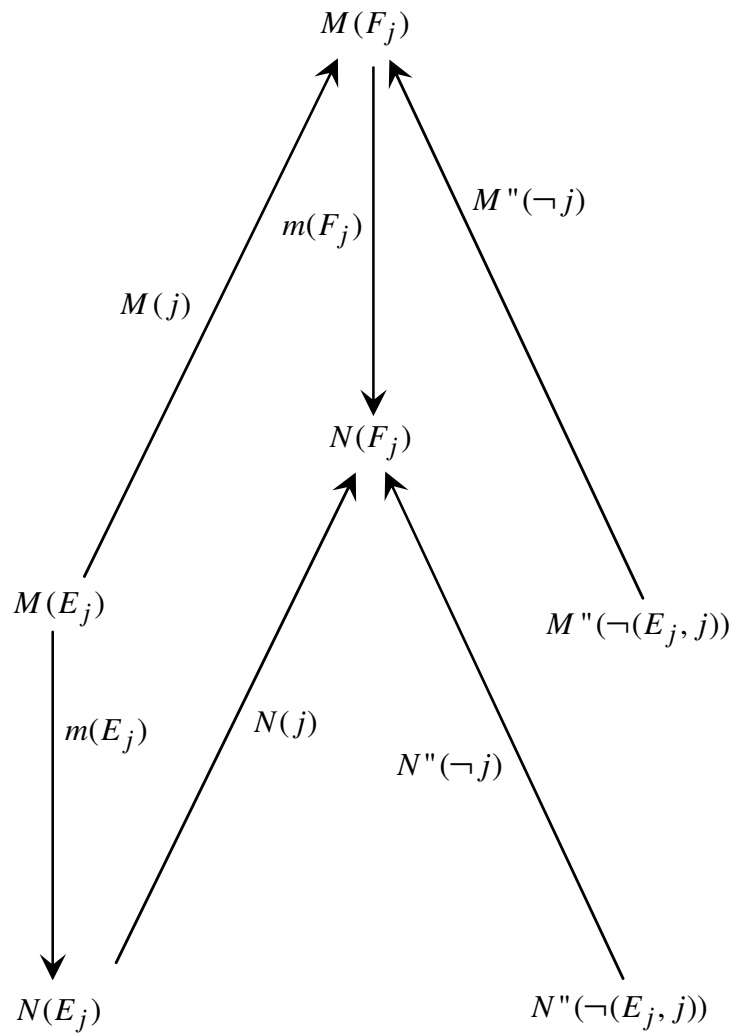

Figure 17

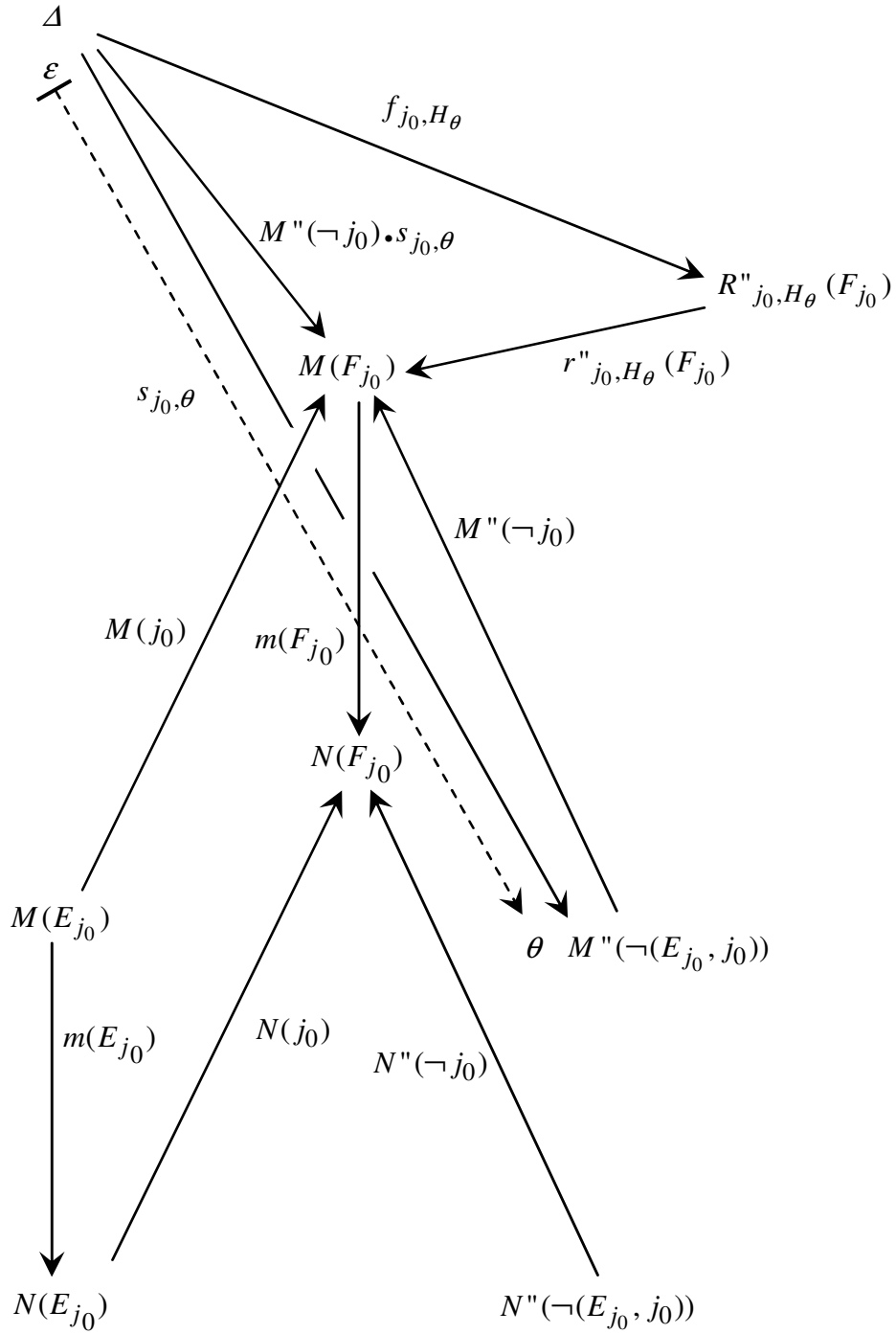

Figure 18

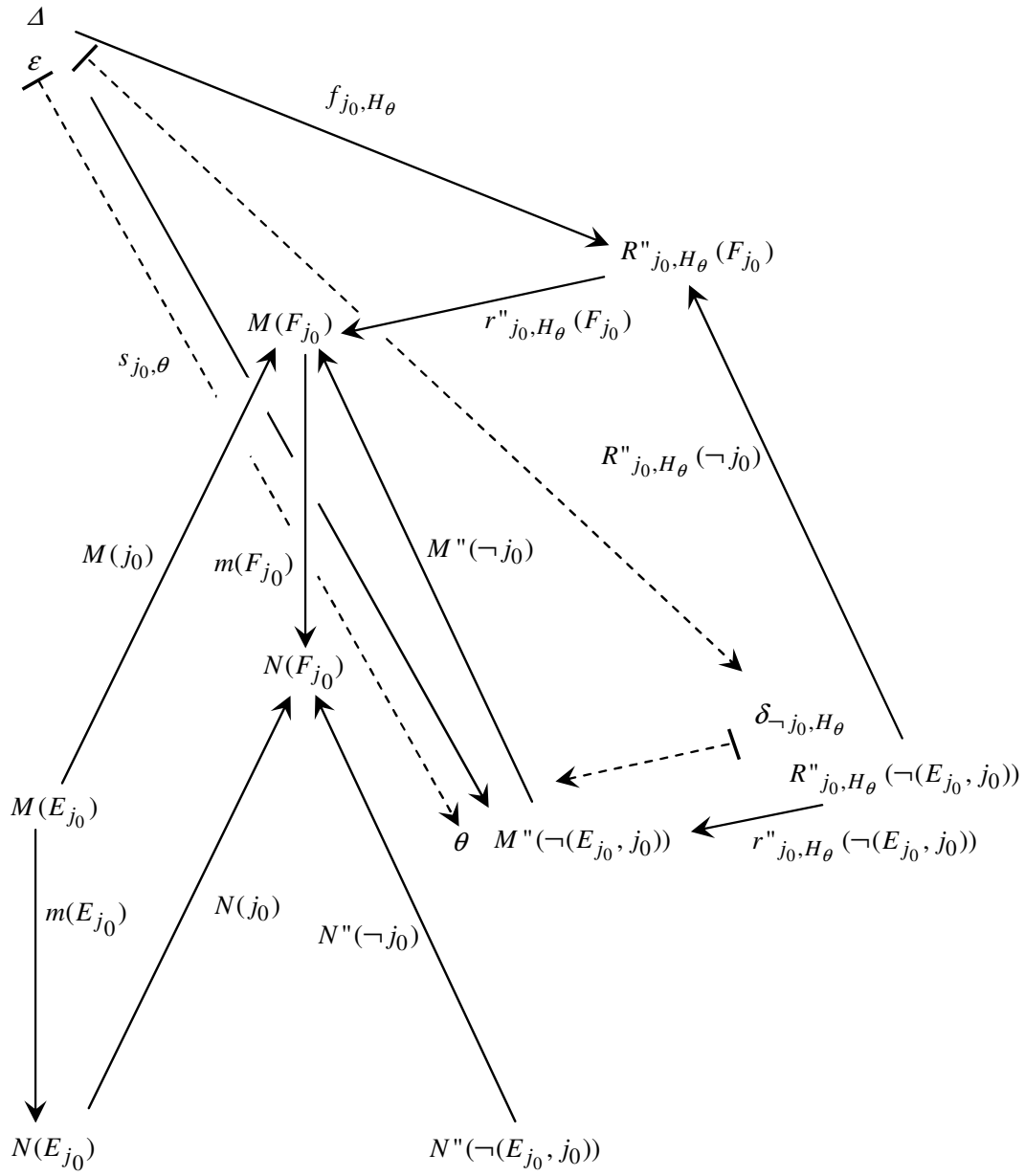

Figure 19

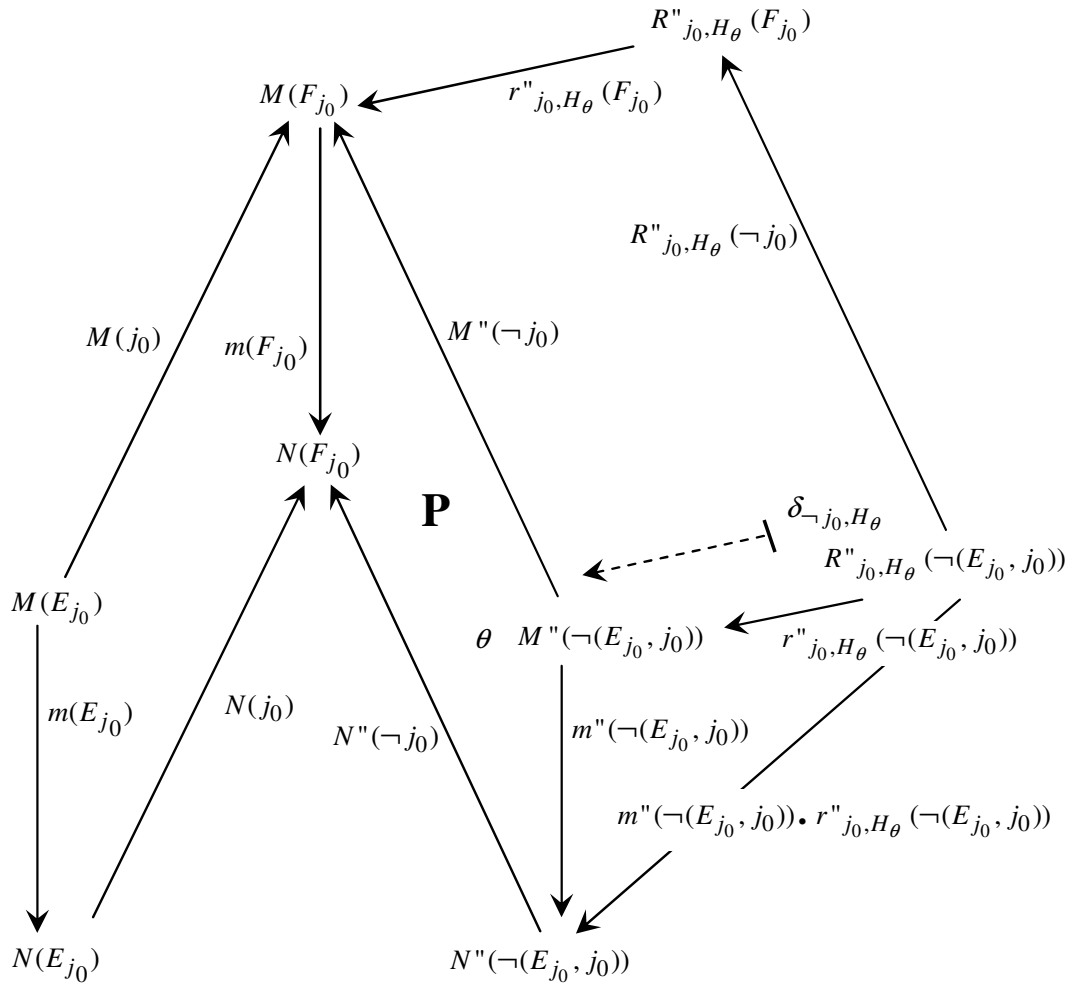
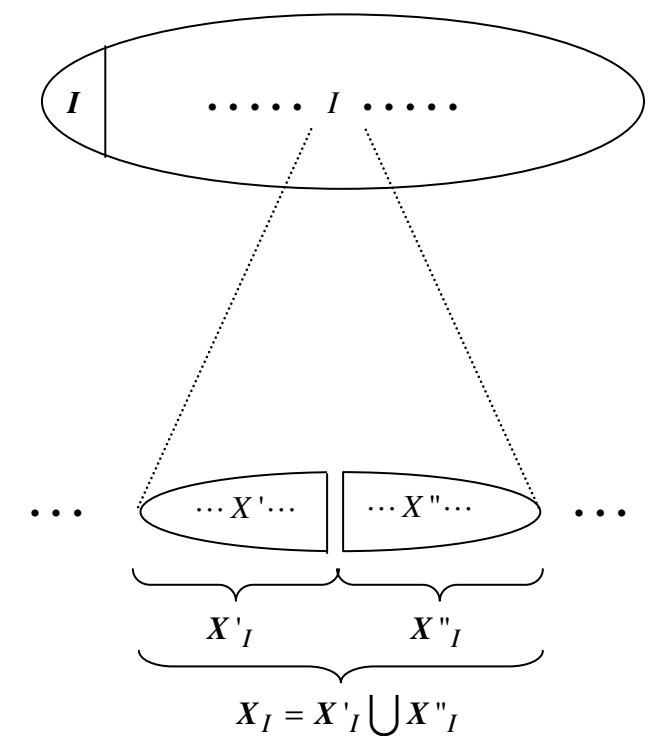
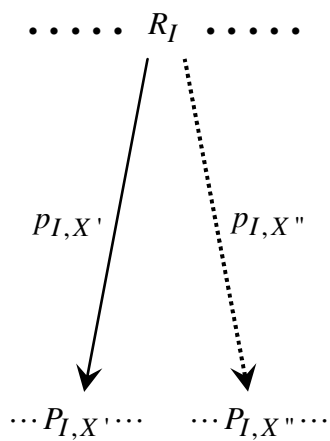

Figure 20



M



$\longrightarrow \in \text{Fl}(M')$
 $\cdots \cdots \longrightarrow \notin \text{Fl}(M')$

Figure 21

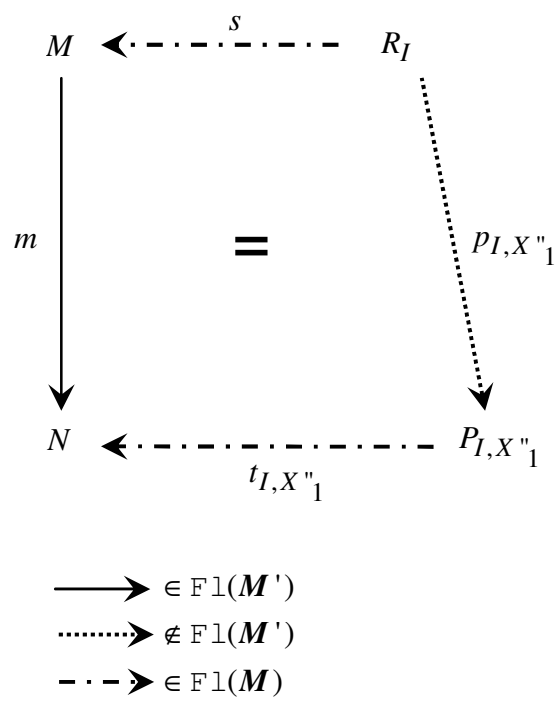

Figure 22

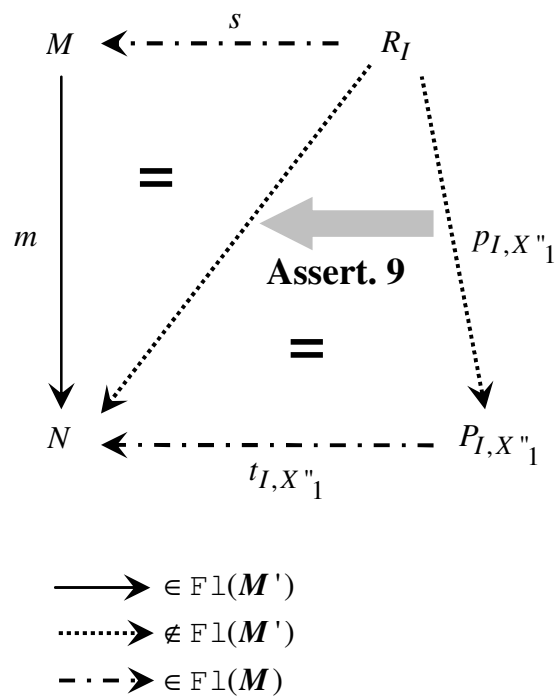

Figure 23

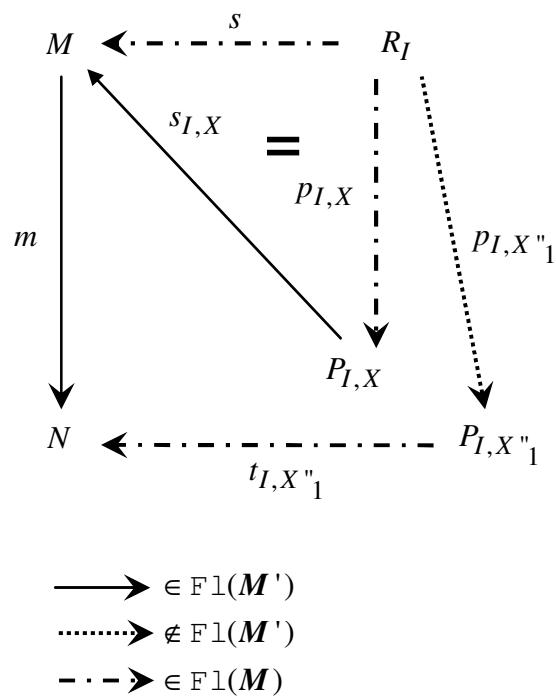
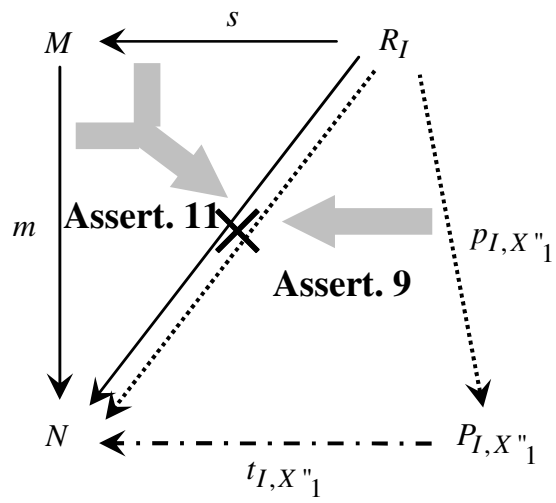
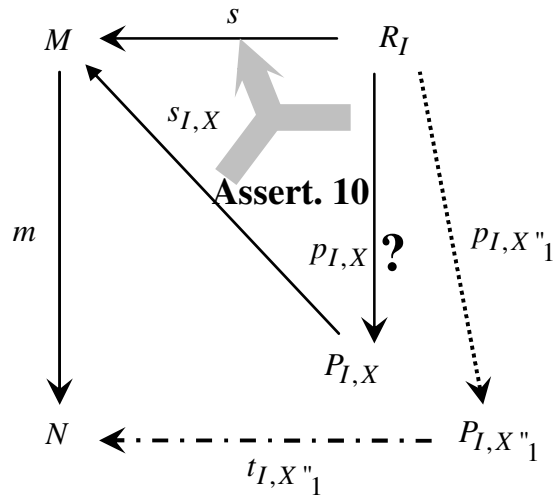
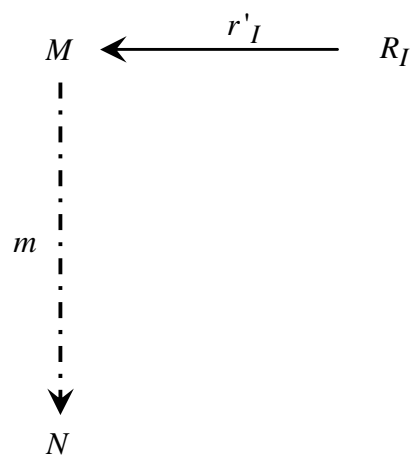

Figure 24



- $\longrightarrow \in \text{Fl}(M')$
- $\cdots\cdots\cdots \notin \text{Fl}(M')$
- $- - - \in \text{Fl}(M)$

Figure 25



$\longrightarrow \in \text{Fl}(M')$
 $\dashrightarrow \in \text{Fl}(M)$

Figure 26

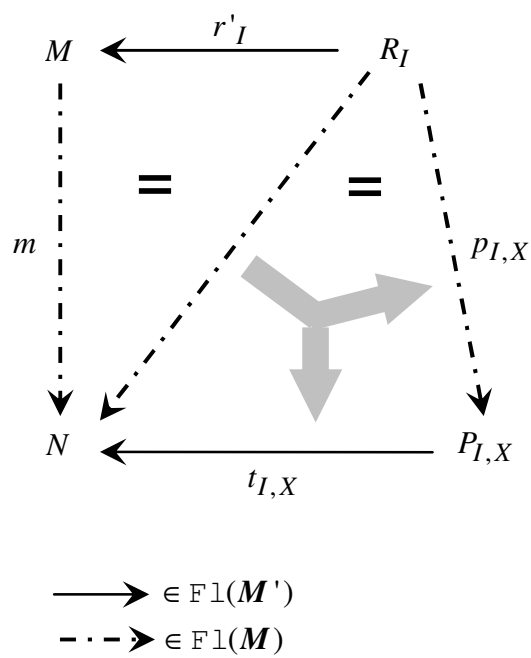

Figure 27

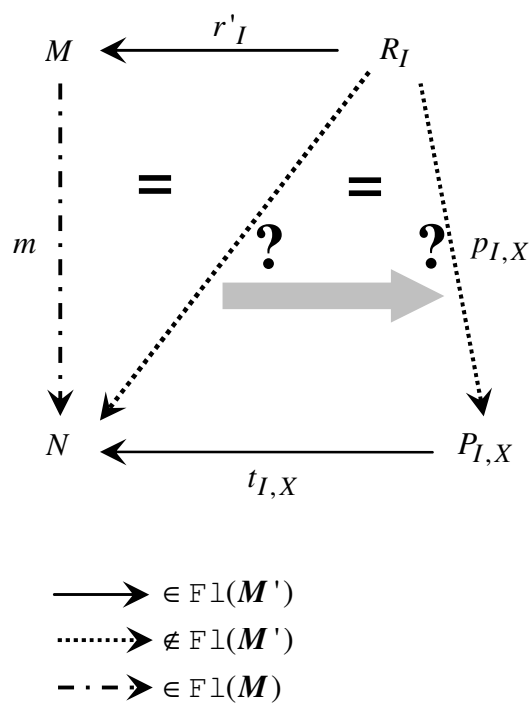

Figure 28

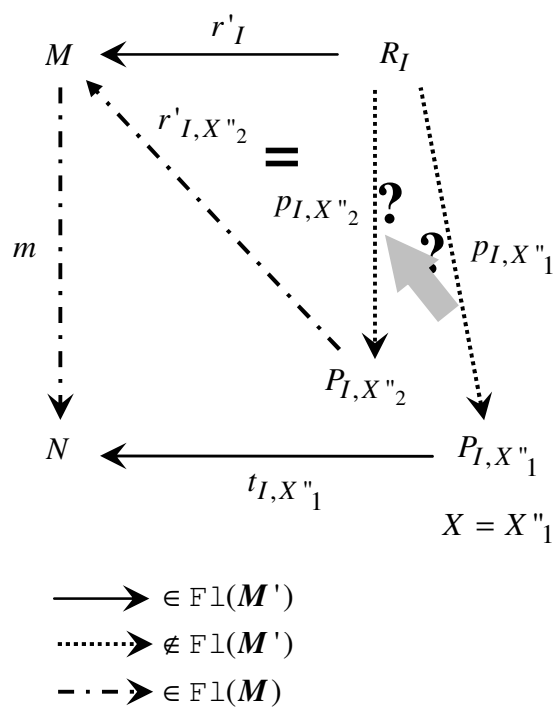

Figure 29

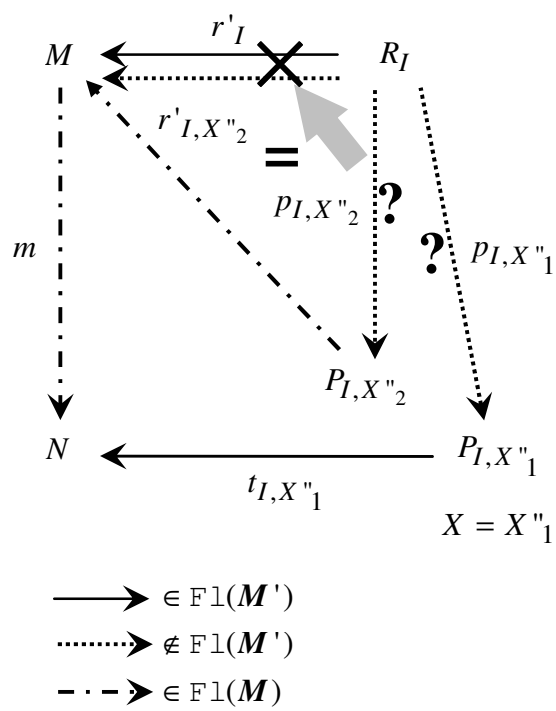

Figure 30

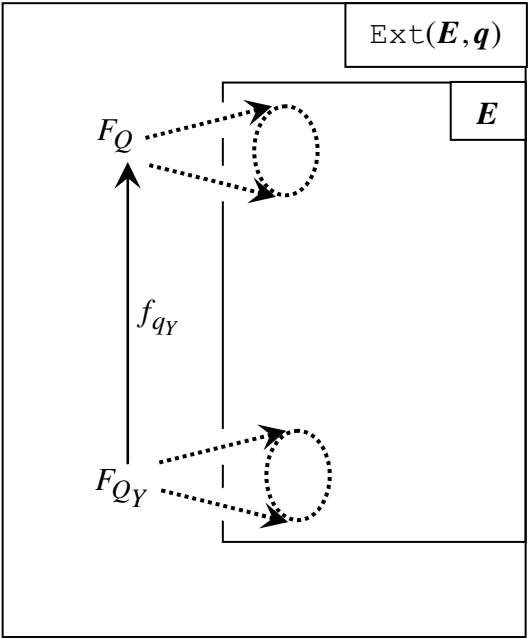

Figure 31

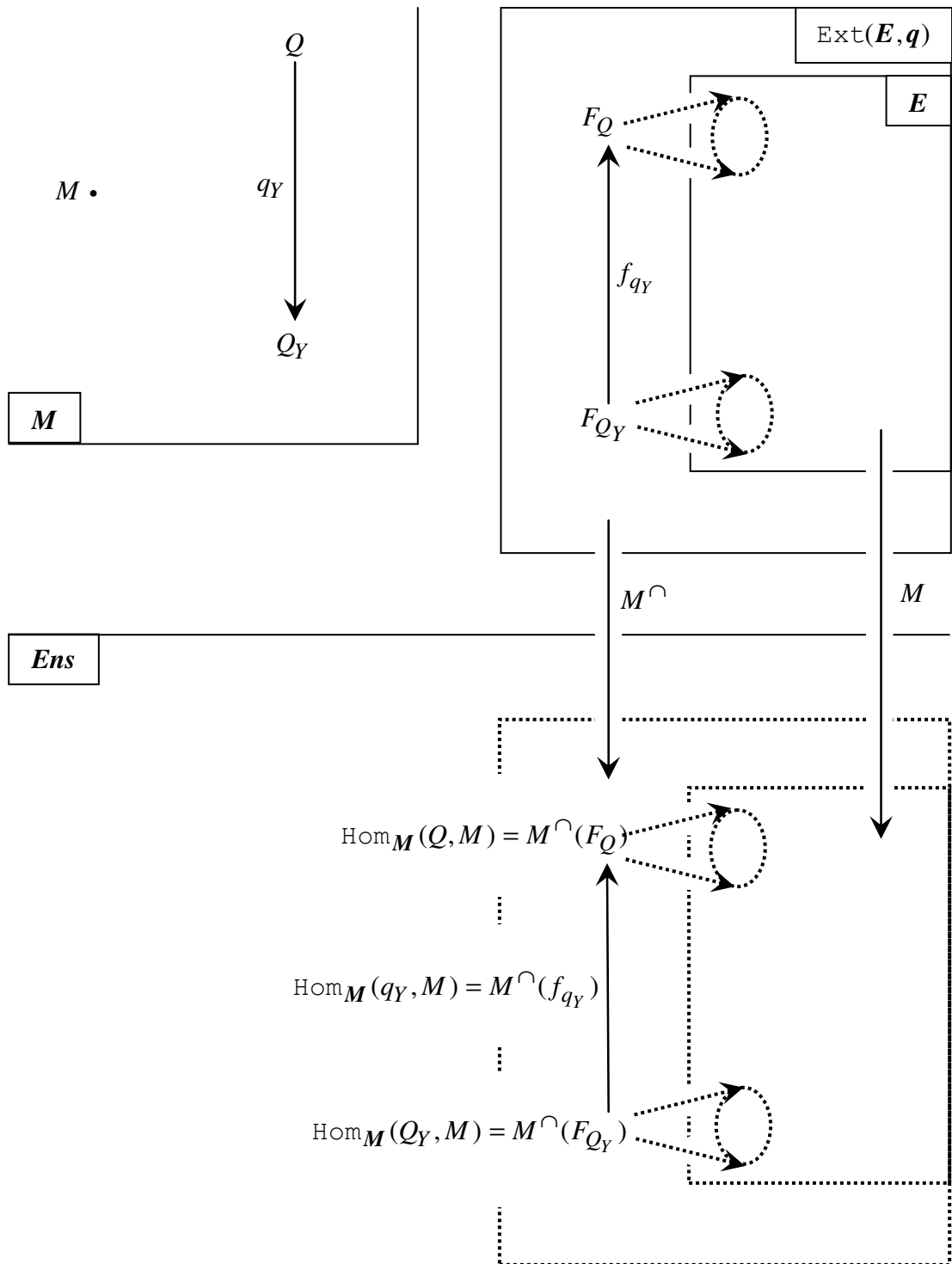

Figure 32

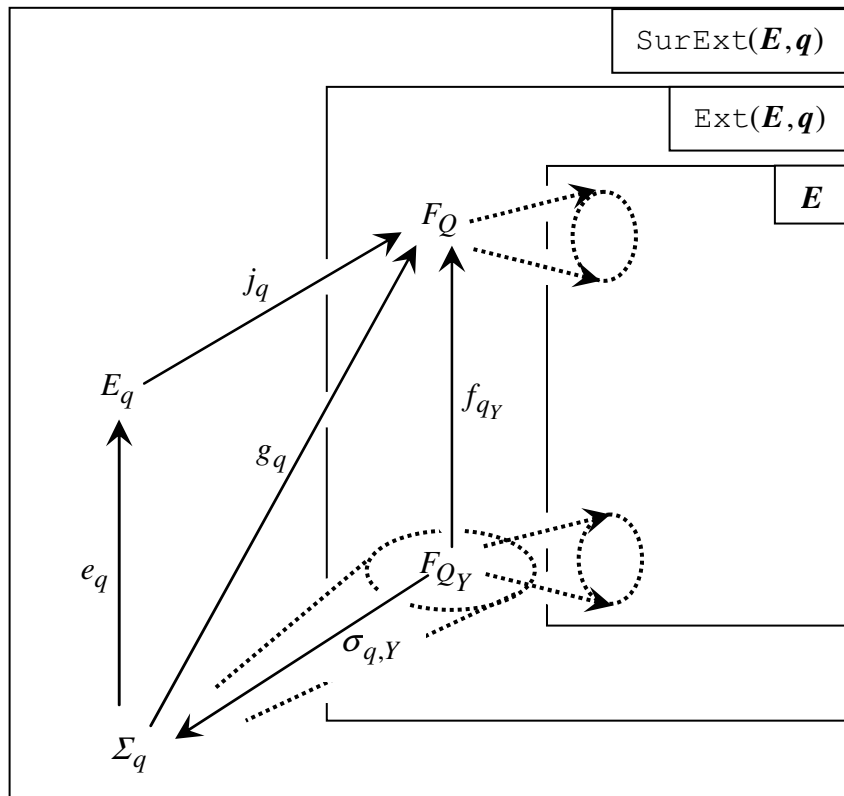

Figure 33

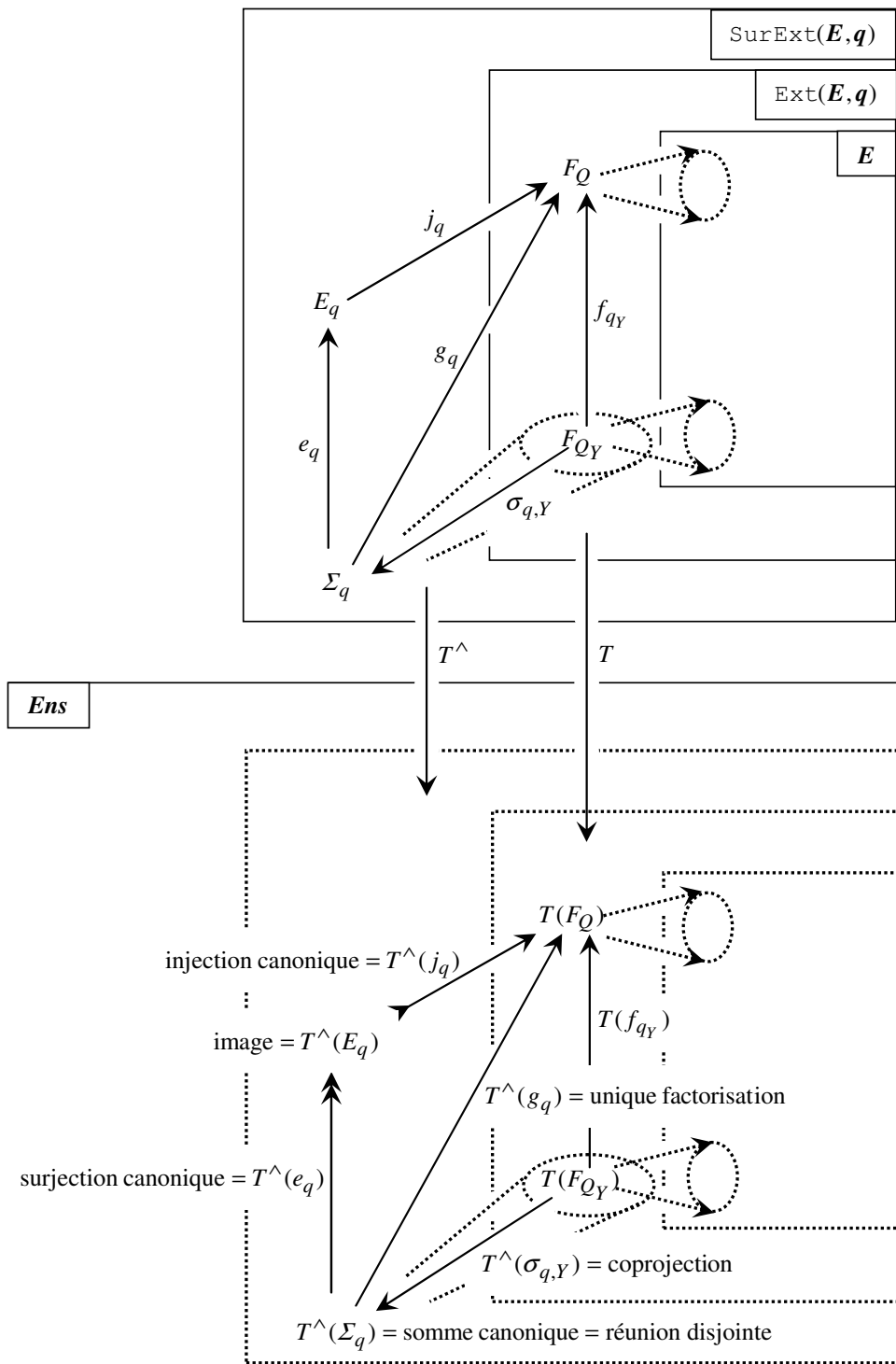

Figure 34

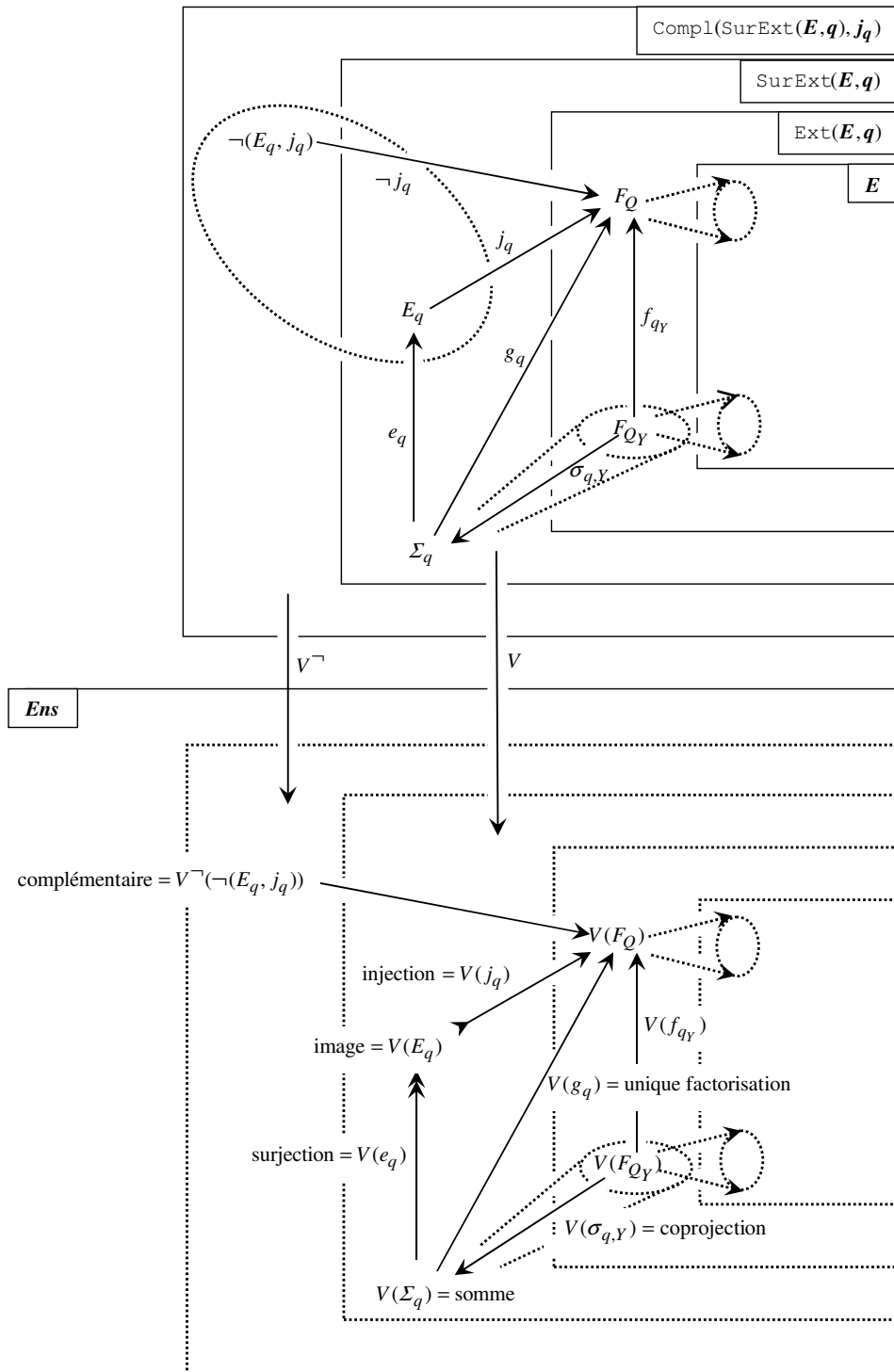

Figure 35

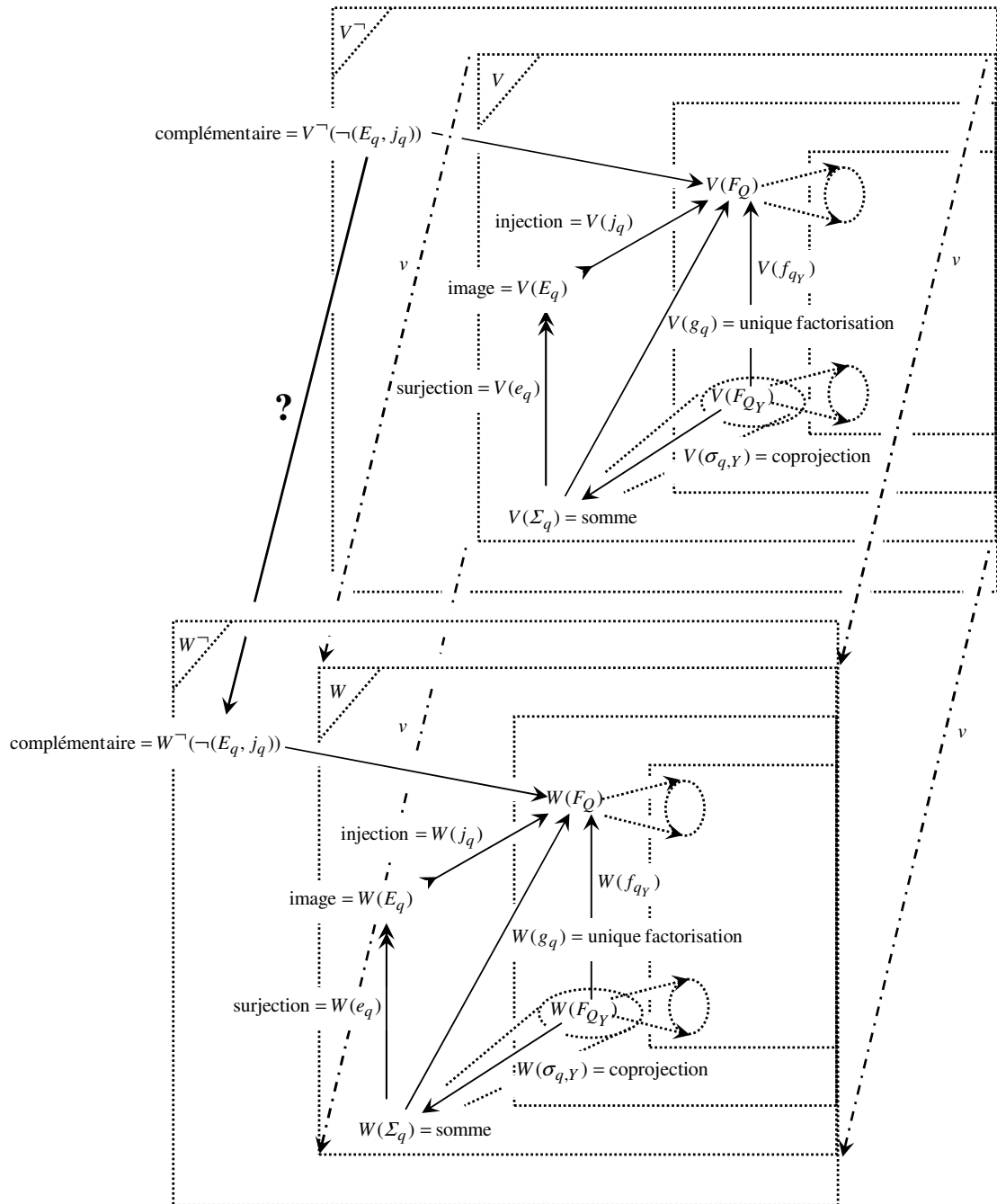

Figure 36