

ANNALES
HENRI LEBESGUE

LUISA PAOLUZZI

CYCLIC BRANCHED COVERS OF ALTERNATING KNOTS

REVÊTEMENTS RAMIFIÉS CYCLIQUES DES
NŒUDS ALTERNÉS

ABSTRACT. — For any integer $n > 2$, the n -fold cyclic branched cover M of an alternating prime knot K in the 3-sphere determines K , meaning that if K' is a knot in the 3-sphere that is not equivalent to K then its n -fold cyclic branched cover cannot be homeomorphic to M .

RÉSUMÉ. — Pour tout entier $n > 2$, le revêtement ramifié cyclique à n feuillets M d'un nœud alterné K contenu dans la 3-sphère détermine K , à savoir si K' est un nœud dans la 3-sphère qui n'est pas équivalent à K , alors son revêtement ramifié cyclique à n feuillets ne peut pas être homéomorphe à M .

1. Introduction

A knot K in the 3-sphere is *alternating* if it admits a generic projection onto a 2-sphere where the double points of the projection alternate between overcrossings and undercrossings when travelling along the knot. In spite of the purely combinatorial character of this definition, being alternating seems to have deep consequences on the topological and geometric properties of the knot. For instance, alternating prime knots cannot be satellite knots [Men84], that is their exteriors are atoroidal. Nonetheless, until fairly recently no description of this class of knots in terms of

Keywords: Alternating knots, prime knots, cyclic branched covers of knots, periodic symmetries of knots.

2020 *Mathematics Subject Classification:* 57K10, 57M12, 57K32, 57K35.

DOI: <https://doi.org/10.5802/ahl.89>

geometric or topological properties was known. A characterisation of alternating knots as the class of knots admitting spanning surfaces with special features was provided independently by Greene [Gre17] and Howie [How17].

In this work, we are interested in studying another topological aspect of alternating knots, namely the behaviour of their cyclic branched covers. Recall that given a knot K in the 3-sphere and an integer $n \geq 2$ one can construct a closed 3-manifold $M(K, n)$ called (the total space of) the n -fold cyclic branched cover of K . We refer the reader to Rolfsen's book [Rol76] for the explicit construction of these manifolds since it will not be needed here (see also [Pao05a] for a survey on cyclic branched covers). In the following we will only need the following fact: there is a map $p : M(K, n) \rightarrow \mathbf{S}^3$ whose restriction $M(K, n) \setminus p^{-1}(K) \rightarrow \mathbf{S}^3 \setminus K$ is a covering map. We point out that the manifolds $M(K, n)$ can be considered as topological invariants of the knot K . It was shown by Kojima in [Koj86] that its n -fold cyclic branched cover $M(K, n)$ determines the prime knot K provided that n is sufficiently large in the following sense: for each pair of prime knots K and K' , there exists an integer $N = N(K, K')$ such that if the manifolds $M(K, n)$ and $M(K', n)$ are homeomorphic for some $n \geq N$, then K and K' are necessarily equivalent.

If the n -fold cyclic branched cover of a knot K does not determine K , that is if there exists another knot K' not equivalent to K such that $M(K, n)$ and $M(K', n)$ are homeomorphic, then we say that K and K' are n -twins.

Kojima's result can thus be restated by saying that a prime knot does not have n -twins if n is large enough. However, it should be stressed that for every integer n there are prime knots, and even hyperbolic knots, that have n -twins (see, for instance, [Nak81, Sak81, Zim98]).

The main result of the paper asserts that cyclic branched covers are strong invariants for alternating prime knots.

THEOREM 1.1. — *Let K be an alternating prime knot. If $n > 2$, then K has no n -twins.*

Before introducing the key ideas of the proof, it is worth mentioning what happens in the situations where the hypotheses of the theorem are not fulfilled, that is if the knots are not prime or if $n = 2$. First of all, this type of result cannot hold for composite knots. Indeed, as shown by Viro [Vir76], it is easy to construct non equivalent composite knots, and even alternating ones, that are n -twins for every $n \geq 2$. This is a consequence of the fact that the construction of cyclic branched covers does not depend on a chosen orientation of the knot. An example of such twins is provided by the connected sum of the non invertible knot 8_{17} (in Rolfsen's notation) with itself and the connected sum of the same knot with its reverse (for the non invertibility of 8_{17} see [KL99]).

Let us now discuss what happens when $n = 2$. As cyclic branched covers of composite knots are not prime while the 3-sphere is irreducible, two n -twins are either both composite or both prime, so the only situation left to consider is that of 2-twins that are prime. Here we are somehow disregarding the case of the trivial knot which is neither composite nor prime (as the unit of the monoid structure induced by the connected sum on the set of oriented knots). One can easily see that, for all $n \geq 2$, the n -fold cyclic branched cover of the trivial knot is the 3-sphere. It follows

then from the positive answer to Smith's conjecture [MB84] that, for every $n \geq 2$, the trivial knot has no n -twins.

Turning our attention to the case of 2-twins of prime knots, we see that Montesinos knots [MA73] admit 2-twins as soon as their Montesinos presentation consists of at least four tangles and at least three distinct tangles appear (this latter condition is not necessary, though). Since alternating Montesinos knots with these properties clearly exist, the conclusion of Theorem 1.1 is false if $n = 2$.

Notice that the given examples of 2-twins are instances of a more general phenomenon called *Conway mutation*: if S is a 2-sphere that meets a knot K in four points, one can remove one of the two 3-balls bounded by S and the tangle it contains and glue it back in a different way, obtaining thus a new knot K' (see for instance [Pao05a, p. 259] for more details on this construction). The new knot K' is obtained from K by *Conway mutation* and is a *Conway mutant* of K . It turns out that K and K' have homeomorphic 2-fold branched covers (see [Vir72]). They need not be 2-twins, for they may be equivalent. For the two knots to be 2-twins, it is necessary (but perhaps not sufficient) that the sphere S is an *essential Conway sphere*, that is its intersection with the exterior of K is incompressible and ∂ -incompressible in the knot exterior. Possibly the most famous Conway mutants that are also 2-twins but not Montesinos knots (nor alternating) are the Conway [Con67] and Kinoshita–Terasaka [KT57] knots.

It was shown by Greene in [Gre13] that two prime alternating 2-twins are necessarily Conway mutants. Greene conjectures that if a prime alternating knot K admits a 2-twin K' then K' is necessarily a Conway mutant of K and, in particular, is itself alternating.

This conjecture is all the more striking if one considers that there is a plethora of phenomena giving rise to 2-twins of a prime knot, as discussed for instance in [Pao05a]. Among the different constructions of 2-twin knots, there is one, originally introduced by Nakanishi [Nak81] and Sakuma [Sak81], that can be exploited to produce n -twins for any $n \geq 2$. Given a two-component link $L = L_1 \cup L_2$ in the 3-sphere both of whose components are trivial knots, one can consider the n -fold cyclic branched cover of the component L_i , $i = 1, 2$. Since L_i is the trivial knot, the manifold $M(L_i, n)$ is the 3-sphere. For $j \neq i$, the preimage of L_j in $M(L_i, n)$ is connected, and thus a knot K_j , provided that n and the linking number of L_1 and L_2 are coprime. If this is the case, by construction the knots K_1 and K_2 have homeomorphic n -fold cyclic branched covers: the manifold $M(K_j, n)$, $j = 1, 2$, is just the $(\mathbb{Z}/n\mathbb{Z} \times \mathbb{Z}/n\mathbb{Z})$ -branched cover of the link L , and its construction does not depend on j since $\mathbb{Z}/n\mathbb{Z} \times \mathbb{Z}/n\mathbb{Z}$ is abelian. Intuitively, if no homeomorphism of \mathbf{S}^3 exchanges the two components of L one can expect K_1 and K_2 to be non equivalent, that is they are genuine n -twins.

The most remarkable fact about this construction was pointed out by Zimmermann in [Zim98]. He proved that, if K is a hyperbolic knot admitting an n -twin K' for some $n > 2$, then K and K' must be obtained as the K_1 and K_2 of Nakanishi and Sakuma's construction just described. This is one of the key points in the proof of the main result. Indeed, prime alternating knots are either hyperbolic or torus knots. As a torus knot and a hyperbolic knot cannot be n -twins if $n > 2$ (see Proposition 4.1 for more details), the two types of knots can be considered separately. It is probably

folklore that the conclusion of Theorem 1.1 holds for torus knots of any kind. We will provide a proof for the sake of completeness in Proposition 4.2 of Section 4. As a consequence, one is only left to deal with the hyperbolic case.

The second key ingredient in the proof of the main result is that certain types of symmetries of prime alternating knots are *visible* on an alternating diagram. The notion of visibility of symmetries on minimal diagrams of prime alternating knots has been considered as a straightforward consequence of the proof of Tait's flyping conjecture (see, for instance, [HTW98]) by Menasco and Thistlethwaite [MT93].

In our case, we need certain symmetries, i.e. *periods* (see Section 2 for the definition), to be visible in a very specific sense (see Section 2 for the actual definition of visibility we need). A detailed proof of this fact was given recently by Costa and Quach Hongler in [CQH19] (see also [Boy19] for the case of symmetries of odd prime order). The importance of this fact as a central tool in the proof becomes clear once we restate the aforementioned result of Zimmermann's in the following way. Let K be a hyperbolic knot and $n > 2$. K admits an n -twin if and only if K admits an n -period ψ such that the quotient knot $K/\langle\psi\rangle$ is the trivial knot and no homeomorphism of \mathbf{S}^3 exchanges the components of the link $(K \cup \text{Fix}(\psi))/\langle\psi\rangle$. Incidentally, we note that prime satellite n -twins, with $n > 2$, need not be related in this way according to the examples given in [BP08].

The organisation of the paper is the following. In Section 2 we show that if an alternating knot K admits a period ψ which is visible on a minimal alternating diagram and such that $K/\langle\psi\rangle$ is the trivial knot, then the quotient admits a diagram of a specific form. This uses properties of alternating diagrams of the trivial knot. In Section 3, we exploit the structure of the link $(K \cup \text{Fix}(\psi))/\langle\psi\rangle$ determined in the previous section to show that there is a homeomorphism of \mathbf{S}^3 exchanging its components. Finally, in Section 4 we prove Theorem 1.1.

2. Quotient diagrams of prime alternating knots via special periodic symmetries

In this section we determine a diagram of the quotient of an alternating knot K by the action of a period under the hypotheses that the period is visible on a minimal alternating diagram for K and the quotient knot is trivial.

We need the following definitions.

DEFINITION 2.1. — *A period of order n or n -period of a knot K is an orientation preserving diffeomorphism ψ of order $n \geq 2$ of the 3-sphere which leaves K invariant and such that its fixed-point set $\text{Fix}(\psi)$ is a circle disjoint from K .*

DEFINITION 2.2. — *Let K be a knot admitting a period ψ of order n . We say that ψ is visible on a diagram D for K if there exist*

- a 2-sphere S embedded in \mathbf{S}^3 ,
- two points, $p, q \in \text{Fix}(\psi)$, one on each side of S ,
- a product structure $\mathbf{S}^2 \times (-1, 1)$ of $\mathbf{S}^3 \setminus \{p, q\}$, for which $S = \mathbf{S}^2 \times \{0\}$,

such that the projection $p : \mathbf{S}^2 \times (-1, 1) = \mathbf{S}^3 \setminus \{p, q\} \longrightarrow \mathbf{S}^2 \times \{0\} = S$ satisfies $p(K) = D$, and moreover $\psi(S) = S$ and there is a diffeomorphism $\hat{\psi} : S \longrightarrow S$ of order n such that $\hat{\psi} \circ p = p \circ \psi$.

More generally, one might want to consider arbitrary *symmetries* of a knot, that is finite groups of diffeomorphisms of the 3-sphere that leave the knot invariant. For a symmetry to be *visible* it would then mean that the projection sphere S is left invariant by the symmetry and the symmetry “commutes” with the projection, inducing a symmetry of (S, D) . However, certain symmetries cannot be visible in this sense. For instance, this is the case if the symmetry is a cyclic group of order $n > 2$ acting freely, for such a group cannot leave invariant a 2-sphere.

Figure 2.1 shows a schematic diagram where a 6-period is visible. The dot in the middle is one of the two intersections of the fixed-point set of the period with the sphere of projection. The crossings of the knot can be arranged to sit inside six equal tangles, represented by rectangles in the figure, that are permuted by the period which acts on the sphere as a rotation about the central dot (and the point at infinity).

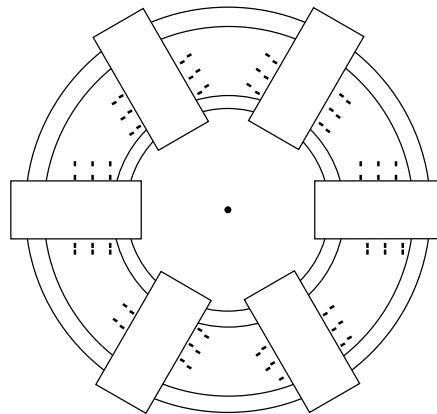

Figure 2.1. A schematic diagram where a 6-period is visible.

For simplicity, in the following we will abuse notation and write ψ even when referring to $\hat{\psi}$.

PROPOSITION 2.3. — *Let K be a non trivial prime alternating knot with period ψ of order n . Assume that ψ is visible on a minimal diagram D for K and that $K/\langle\psi\rangle$ is the trivial knot. Then, up to diagram isotopy relative to the axis, the diagram $D/\langle\psi\rangle$ is alternating and of the form shown on the left-hand side of Figure 2.2, where the dot represents the axis of ψ and each box a sequence of crossings.*

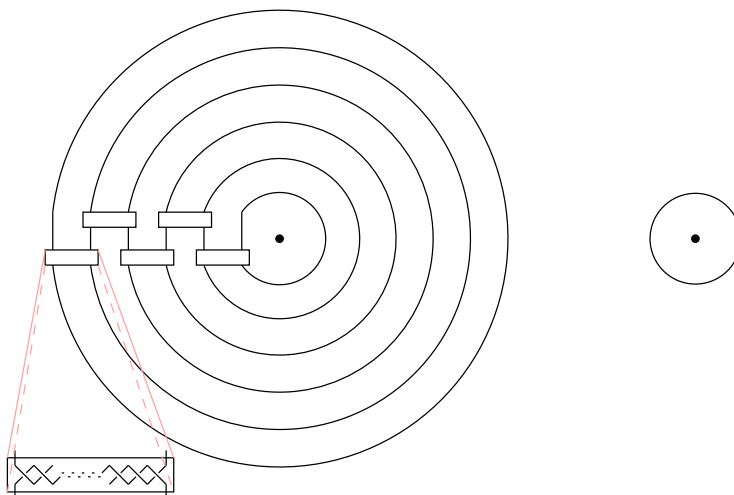

Figure 2.2. The structure of the diagram $D/\langle\psi\rangle$ of the quotient knot $K/\langle\psi\rangle$ for a tangle of size $k = 5$ on the left, and the case $k = 1$ on the right. Each rectangular box represents a sequence of crossings.

Before proving the proposition, let us explain the structure of the diagram on the left-hand side of Figure 2.2. The central dot represents one of the two intersections of $Fix(\psi)/\langle\psi\rangle$ with the sphere of projection, the other being the point at infinity. Each box represents a horizontal (with respect to the picture) sequence of crossings, as suggested by the drawing below the diagram. Remark that because the diagram is alternating the sign of crossings in one box constrains the signs of the crossings in all other boxes. This means that each diagram is determined, up to taking a mirror, simply by the *size k of the tangle*, i.e. number of arcs, and the number of crossings in each of the $k - 1$ boxes. Observe also that if the roles of the two intersection points of $Fix(\psi)/\langle\psi\rangle$ with the sphere of projection are exchanged, then the diagram changes (the size is the same, while the numbers of crossings in the boxes appear in reversed order) but its structure stays the same. Indeed, the boxes in the picture are alternately located below and above with respect to each other, but this relative position can be changed since the boxes can be slid around the dot by an isotopy of the 2-sphere leaving the intersections with $Fix(\psi)/\langle\psi\rangle$ fixed.

Proof. — Clearly, $D/\langle\psi\rangle$ is the closure of a tangle by means of k arcs going around the axis, as shown in Figure 2.3 with the axis represented as usual by a dot. We observe that $D/\langle\psi\rangle$ must moreover enjoy the following extra properties: it is an alternating diagram representing the trivial knot. In particular, it must present a Reidemeister I move allowing to reduce the number of crossings according to [Ban30]. The move cannot take place inside the tangle, else D would not be minimal. So the loop involved in the move must contain the dot corresponding to the axis of the period. The proof will be by induction on k , the size of the tangle, in a diagram of the form and with the properties just discussed.

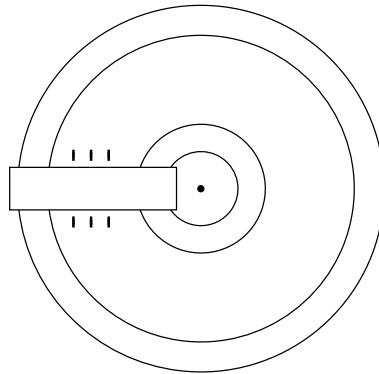

Figure 2.3. The diagram $D/\langle\psi\rangle$ is the quotient of the diagram D pictured in Figure 2.1 by the action of the period and is itself the closure of a tangle.

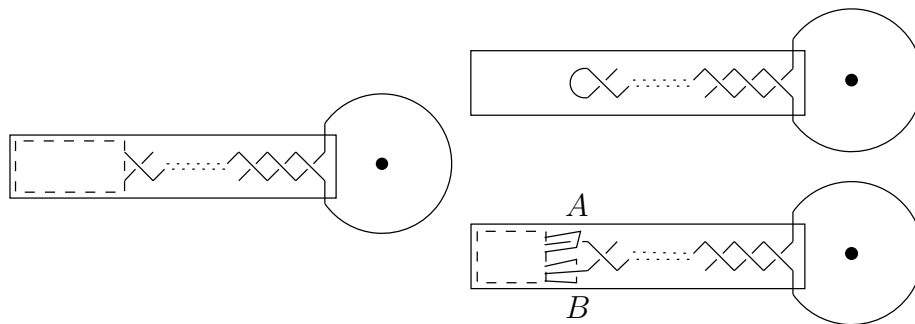

Figure 2.4. The case $k = 1$ where crossings are present. A maximal string of crossings adjacent to the nugatory one is put in evidence. If there is no other crossing the situation is as pictured on the top-right, else the two arcs exiting the maximal string must encounter two distinct crossings labelled A and B as pictured on the bottom-right.

If $k = 1$ we want to prove that the tangle must consist of a straight arc, that is the diagram has no crossings (as in the right-hand side of Figure 2.2); in particular, this situation cannot arise under the hypotheses of the proposition, for K would be trivial in this case. If that is not the case, then the situation is as shown in Figure 2.4 where a maximal string of half-twists adjacent to the loop involved in the Reidemeister I move is put in evidence. If there are no other crossings inside the tangle, then the diagram must be of the form shown on the top-right of Figure 2.4. So assume there are other crossings inside the tangle. The situation must be as in the bottom-right of Figure 2.4, where the crossings A and B must be distinct, since the string of half-twists was chosen to be maximal. At this point we see that either a nugatory crossing was already present inside the tangle, against the hypothesis, or no Reidemeister I move can be performed, once more contradicting the hypothesis, since the knot would not be trivial.

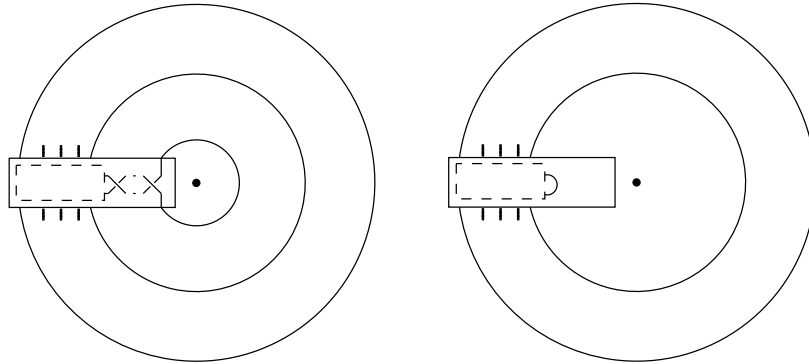

Figure 2.5. A new diagram with a tangle of size $k - 1$ (shown on the right-hand side) can be obtained by performing a sequence of Reidemeister I moves that eliminate a maximal sequence of nugatory crossings (shown on the left-hand side).

We can now assume $k \geq 2$ and that, up to isotopy, the situation is thus as shown in Figure 2.5 where, as in the case where $k = 1$, a maximal string of half-twists adjacent to the loop involved in the Reidemeister I move is put in evidence.

We point out that it may be necessary to perform some isotopy relative to the axis of symmetry to have the exact diagram shown in Figure 2.5, for the initial diagram may be as illustrated in Figure 2.6. The isotopy will consist in performing a series of Dehn twists about a loop encircling the central dot. Note that the isotopy also reduces the size of the tangle, so one might also just assume that the diagrams are chosen in their isotopy class to have a tangle of minimum size.

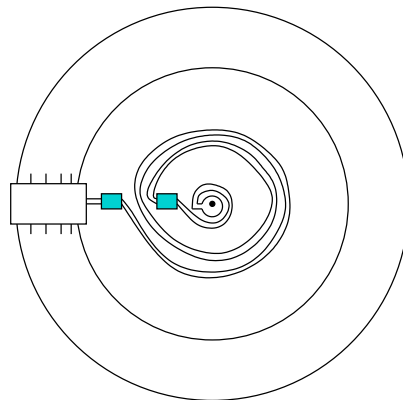

Figure 2.6. To obtain the diagram of Figure 2.5 one may need to perform an isotopy first in order to unwind the coil at the centre. The maximal sequence of nugatory crossings can be split into smaller sequences along the coil, represented here by coloured boxes. After the isotopy the size of the tangle may decrease.

If we remove the crossings as suggested in the figure by performing as many Reidemeister I moves as the number of crossings, we get a new diagram for the trivial knot, obtained by closing a $(k - 1)$ -tangle around an axis. We claim that this new alternating diagram satisfies the same properties as the original one so that we may apply the induction hypothesis to finish the proof. The argument is similar to that of the previous case.

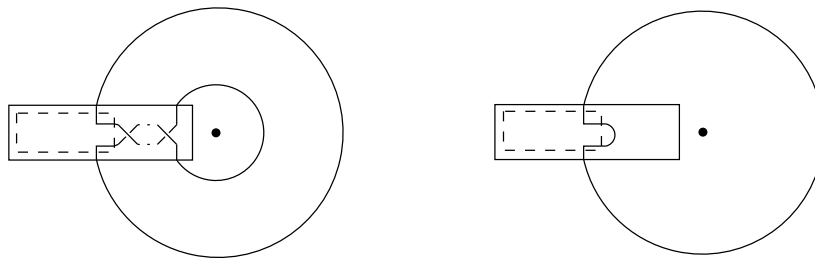

Figure 2.7. In the situation where $k \geq 2$ and, apart from a sequence of nugatory crossings, no other crossing is present, Figure 2.5 looks as shown here. In this case one must have $k = 2$.

If there is no other crossing, the only possibility is that $k = 2$ and the situation is as in Figure 2.7 which is precisely of the form given in Figure 2.2, else, that is if $k > 2$, we would have a link with more than one component.

We can thus assume that there are other crossings inside the tangle as in Figure 2.8. The main point is that there must be a nugatory crossing somewhere in the modified diagram, but such crossing cannot be already present in the diagram before modification. Because of that, the crossing must be adjacent to both ends of the arc obtained by untwisting the maximal string of half-twists. This implies that the crossings A and B adjacent to this arc (see Figure 2.8 top) must coincide. Note that if A and B do not coincide, then a contradiction is reached as in the $k = 1$ case, albeit now the arc between A and B may go around the dot representing the axis (see Figure 2.8 centre-right). So A and B are the same crossing and, because the string of half-twists was chosen to be maximal, the only possibility is that a strand coming out from the maximal string of half-twists goes around the dot representing the axis before coming back to cross the second strand, as shown in Figure 2.8 bottom. This ensures that the new diagram is of the desired form.

We are now left to understand why the original diagram is also of the desired form. In principle, the sequence of crossing removed in the process could be inserted in two distinct ways (see Figure 2.8 bottom). It is thus enough to show that the two situations are isotopic via an isotopy that preserves the dot, i.e. the projection of the axis of rotation. This is clear from the figure and the discussion preceding the proof of Proposition 2.3. □

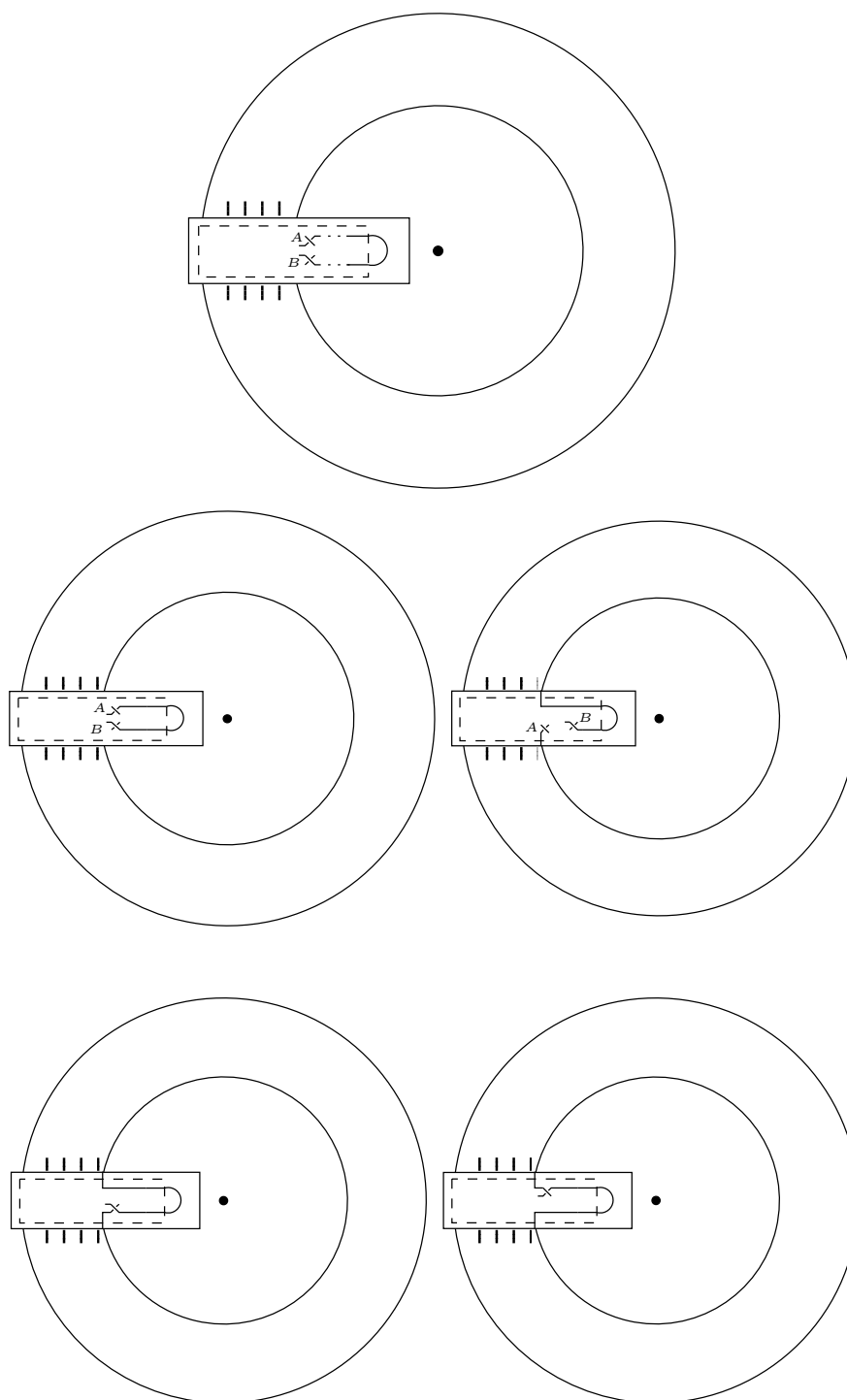

Figure 2.8. The diagram of the right-hand side of Figure 2.5 when other crossings are present. The situation in which the crossings adjacent to the arc obtained after untwisting the maximal string of half-twists are not the same is pictured in the middle, while the case where they coincide is shown on the bottom.

3. Symmetry of the quotients

In this section we study the link having a diagram of the form determined in the previous section.

PROPOSITION 3.1. — *Let K be a non trivial prime alternating knot with period ψ of order n . Assume that ψ is visible on a minimal diagram D for K and that $K/\langle\psi\rangle$ is the trivial knot. Then there is homeomorphism of the 3-sphere that exchanges the two components of the link $(K \cup \text{Fix}(\psi))/\langle\psi\rangle$.*

Proof. — By hypothesis, Proposition 2.3 applies and we know that $(K \cup \text{Fix}(\psi))/\langle\psi\rangle$ admits a diagram as in Figure 2.2 where the second component is represented by the central dot. The second component of the link is a trivial knot that encircles the k arcs that close up the tangle. This is pictured in the left-hand side of Figure 3.1, where an isotopy was performed so that the sequences of half-twists appear alternately on the right and left.

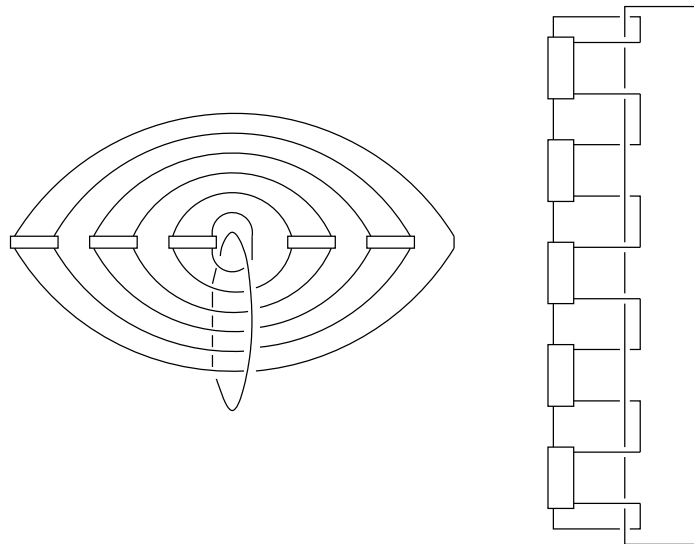

Figure 3.1. Two diagrams of the link $(K \cup \text{Fix}(\psi))/\langle\psi\rangle$ as seen from above and from the side, respectively.

To prove the assertion, it is suitable to modify the given diagram as in the right diagram of Figure 3.1. One can think of the two diagrams as projections of the link from above and from the side respectively. To visualise how to pass from the diagram pictured on the left-hand side to the one on the right-hand side it is convenient to imagine that the central part of the diagram on the left is at the top and the link is located lower and lower down the further we move away from the centre. The sequences of half-twists (i.e. the boxes) on the right are moved to the left by making them pass behind the second component of the link. All sequences of half-twists are now arranged vertically, rather than horizontally.

As pointed out to me by referee A, the right diagram of Figure 3.1 is a four-plat description of the link. This means that $(K \cup \text{Fix}(\psi))/\langle\psi\rangle$ is a 2-bridge link [BZ03, Remark, p 146 & § 12A] and thus, as the closure of a rational tangle, its components are exchangeable [Cro04, Theorem 8.2.1].

This is enough to reach the desired conclusion. In what follows, we give nonetheless a direct proof in our specific case.

The idea is to show that one can transfer the crossings of the $K/\langle\psi\rangle$ component onto the $\text{Fix}(\psi)/\langle\psi\rangle$ component so that afterwards the second component looks like the first one used to, meaning that after a π -rotation in a vertical axis contained in the plane of the figure we end up with the diagram we started with, ensuring that the two components can be exchanged. This can be done as explained in Figure 3.2.

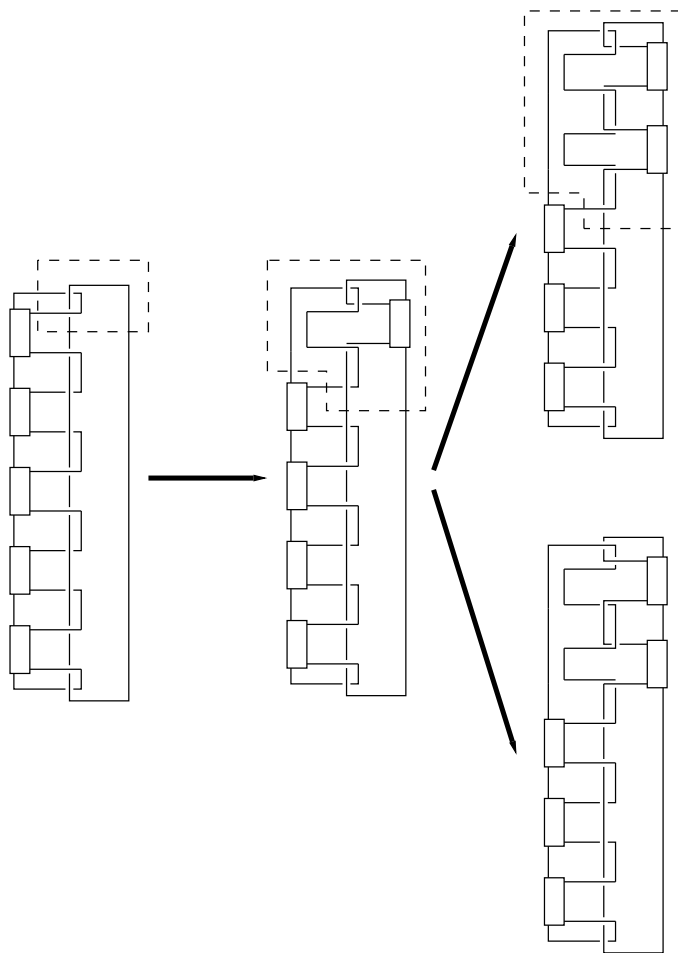

Figure 3.2. Moving crossings from the first component to the second one and the result according to the parity of the number of crossings.

Starting from the top, we consider the first sequence of crossings that appears and transfer the crossings on the other side by performing flypes on the tangle in the dashed box drawn on the left-hand side of Figure 3.2. The result is the central

diagram in Figure 3.2. We can now repeat the same process with the next sequence of half-twists by performing flypes with respect to the tangle delimited by the dashed curve in the central diagram. It turns out that the result depends on the parity of the number of flypes we perform, i.e. crossings in the box. The result in the case of an even number of crossings is shown on the top right-hand side of Figure 3.2, while the case of an odd number is given on the bottom. One can see that the structure is exactly the same in the case of an even number of crossings, but that is not the case if the number is odd. This phenomenon occurs only from the second sequence of half-twists onward, though, as the parity of the number of crossings in the first sequence does not matter.

We conclude that the resulting diagram will look as the original one with the two components exchanged provided that the number of crossings is even in each box except perhaps the first one. Indeed, after moving all crossings from one side to the other and rotating the link of π about a vertical axis contained in the plane of the diagram, we go back to the original diagram, but now with the two components exchanged.

To reach the desired conclusion, we need to understand whether it is possible to assume that the number of crossings is always even, except perhaps in the first box at the top.

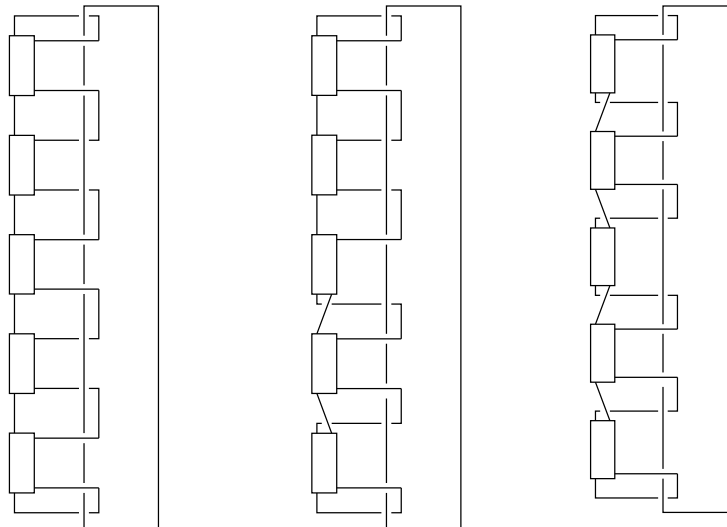

Figure 3.3. How to change the parity of the number of crossings contained in a box.

Figure 3.3 shows how to change the parity of the number of crossings in the sequences, so that all boxes, except perhaps the first one, contain an even number of crossings. Consider the diagram shown on the right-hand side of Figure 3.3 and assume that we want to change the parity of the number of crossings in the last box at the bottom. To achieve that, take the next box and make it go around the arc of the second component by passing it either first under and then over (as in the situation we are considering) or first over and then under (if we were to move, say,

the central box). The result is shown in the central diagram of Figure 3.3 where we see that the number of crossings of the adjacent boxes has changed by one. One might now want to repeat this operation whenever needed to change the parity of the number of crossings in the boxes starting from the bottom and going up. Unfortunately, this is not possible right away. Indeed, the central box of the central diagram is not positioned as the boxes of the diagram on the left-hand side, so it cannot be moved as explained. In fact, one remarks that in the initial diagram the boxes of the first component are positioned in such a way that they alternate between boxes lying “above” with respect to the second component and boxes lying “below”.

To restore the same structure as in the original diagram for all the boxes above those already successfully modified, it is necessary to move not only one box, but all those preceding it that are an even number of boxes away from it. In this specific example, when we move the second box from the bottom, we have to move the second box from the top as well. The result is the diagram on the right-hand side of Figure 3.3. On the other hand, if we had to move the central box, we would need to move the first box at the top as well. The effect of this will be that the positions of all the boxes above the one we are dealing with will be exchanged: those which used to lie above with respect to the second component will end up below, and vice versa. This way, we also only change the parity of the number of crossings in the box we are considering and possibly that of the first box at the top.

Note that this process can change the type of crossings between the two components, but regardless of what these are they will be preserved when performing an even number of flypes anyway.

This achieves the proof of the Proposition 3.1. \square

Remark 3.2. — In view of referee A’s remark, one might wonder whether all 2-bridge links give rise to alternating knots with trivial quotients via Nakanishi and Sakuma’s construction. This is however not the case. The reader can verify that the non alternating knot 9_{49} (in Rolfsen’s notation) admits a 3-period with quotient link 7_1^2 (perhaps up to appropriate choices of mirror images), which is the 2-bridge link of rational invariant $5/14$.

4. Proof of Theorem 1.1

We are now in a position to prove Theorem 1.1.

Let K be a prime alternating knot and let $n > 2$ be an integer. By [Men84], we know that K is either a torus knot or a hyperbolic knot. More precisely, if K is a torus knot, then it must be a $(2, 2m + 1)$ -torus knot, all other torus knots being non alternating as shown by Murasugi [Mur58, Theorem 3.2].

The first step in the proof of the theorem consists in showing that if K' is a n -twin of K then K' is the same type of knot as K , that is a torus knot (if so is K), or a hyperbolic knot (if so is K).

PROPOSITION 4.1. — *Let $n > 2$. A torus knot and a hyperbolic knot cannot be n -twins.*

Proof. — Assume first that K is a torus knot. For all $n \geq 2$ the n -fold cyclic branched cover $M(K, n)$ of K is a Seifert fibred manifold. More precisely it is a *Brieskorn manifold* (see [Mil75, Lemma 1.1]). On the other hand, if K is a hyperbolic knot and $n > 2$, it follows from Thurston's orbifold theorem (see [BLP05, BMP03, BP01, CHK00] for a proof) that $M(K, n)$ is a hyperbolic manifold, provided that $M(K, n)$ is not the 3-fold cyclic branched cover of the figure-eight knot 4_1 . Since a 3-manifold cannot admit both a Seifert fibred structure and a hyperbolic one, to prove the proposition we only need to show that the figure-eight knot does not have a 3-twin that is a torus knot. Indeed, it is a well-known consequence of Dunbar's classification of geometric orbifolds in [Dun88] that the knot $K = 4_1$ has no 3-twins at all. \square

The following result deals with the case of arbitrary torus knots.

PROPOSITION 4.2. — *Let $n \geq 2$. Two torus knots cannot be n -twins.*

We postpone the proof of the proposition at the end of this section. At this point we just remark that, if on the one hand the proposition suffices to ensure that a torus knot cannot have n -twins for $n > 2$ because of Thurston's orbifold theorem, on the other, there are torus knots that have 2-twins that are (hyperbolic) Montesinos knots. Observe that 2-fold branched covers of hyperbolic knots need not be hyperbolic, and can be Seifert fibred or even toroidal. Alternating torus knots, however, do not have twins at all since they are 2-bridge knots. Indeed, Hodgson and Rubinstein proved in [HR85] that 2-bridge knots are determined by their 2-fold cyclic branched covers.

Let K be hyperbolic and assume by contradiction that K is not determined by its n -fold cyclic branched cover. It ensues from the discussion in the proof of Proposition 4.1 that $M(L, n)$ must be a hyperbolic manifold, that is K is a $2\pi/n$ -hyperbolic knot. It then follows from [Zim98, Theorem 1] that K admits a period ψ of order n such that the knot $K/\langle\psi\rangle$ is trivial and no orientation preserving homeomorphism of the 3-sphere exchanges the two components of the link $(K \cup \text{Fix}(\psi))/\langle\psi\rangle$. Note that [Zim98, Theorem 1] is stated only for n not a power of 2, but in fact it holds for any $n > 2$ and the proof uses basically the same argument (see, for instance, [Pao05b, Chapter 4]).

Since K is alternating and ψ is a period of order > 2 , it was proved in [CQH19] that ψ is visible on a minimal alternating diagram for K . As a consequence Proposition 2.3 applies as well as Proposition 3.1, providing the desired contradiction.

This ends the proof of the theorem. We can now pass to the proof of the result about torus knots.

Proof of Proposition 4.2. — As already mentioned, the n -fold cyclic branched cover of the $T(a_1, a_2)$ torus knot is the Brieskorn manifold of type $M(a_1, a_2, n)$, as shown in [Mil75, Lemma 1.1]. Proving the proposition boils down to deciding when two Brieskorn manifolds $M(a_1, a_2, n)$ and $M(b_1, b_2, n)$ are diffeomorphic and establishing that they cannot be if $\{a_1, a_2\} \neq \{b_1, b_2\}$. The diffeomorphism classification of Brieskorn manifolds was obtained by W. Neumann in his Ph.D thesis [Neu70, § 9]. For simplicity, in what follows we will use the description provided by Núñez and Ramírez-Losada in [NRL03, Theorem 1]. We will restate their result in a way that is more convenient for us. Let $a_1 \geq 2$ and $a_2 \geq 2$ be two coprime integers, and $n \geq 2$.

Let d_i , $i = 1, 2$, be the greatest common divisor of a_i and n , so that $d = d_1 d_2$ is the greatest common divisor of $a_1 a_2$ and n . The n -fold cyclic branched covering of the (a_1, a_2) -torus knot is a Seifert fibred space with orientable base and exceptional fibres of at most three distinct orders which are moreover pairwise coprime. According to the different properties of d_1 , d_2 , and d , the Seifert invariants of the space satisfy the following conditions.

- (1) If $d = d_1 = d_2 = 1$, then the base of the fibration is the 2-sphere and there is one exceptional fibre of order a_2 , one of order a_1 , and one of order n .
- (2) If one between d_1 and d_2 is equal 1 but the other is > 1 , we can assume without loss of generality that $d_1 > 1$ and $d_2 = 1$ for here a_1 and a_2 play symmetric roles (we are not assuming $a_1 < a_2$, for instance, and of course the (a_1, a_2) -torus knot is equivalent to the (a_2, a_1) -torus knot).
 - (a) If $d = d_1 < a_1$ and $d < n$, then the base of the fibration is the 2-sphere and there are d exceptional fibres of order a_2 , one of order a_1/d , and one of order n/d .
 - (b) If $d = d_1 < a_1$ and $d = n$, then the base of the fibration is the 2-sphere and there are n exceptional fibres of order a_2 , and one of order a_1/d .
 - (c) If $d = d_1 = a_1$ and $d < n$, then the base of the fibration is the 2-sphere and there are d exceptional fibres of order a_2 , and one of order n/d .
 - (d) If $d = d_1 = a_1 = n$, then the base of the fibration is the 2-sphere and there are n exceptional fibres of order a_2 .
- (3) We can now assume that both d_1 and d_2 are > 1 .
 - (a) If $d_1 < a_1$, $d_2 < a_2$, and $d < n$, then the base of the fibration is a surface of genus $g = (d_1 - 1)(d_2 - 1)/2 > 0$ and there are d_1 exceptional fibres of order a_2/d_2 , d_2 of order a_1/d_1 , and one of order n/d .
 - (b) If $d_1 < a_1$, $d_2 < a_2$, and $d = n$, then the base of the fibration is a surface of genus $g = (n + 1 - d_1 - d_2)/2 = (d_1 - 1)(d_2 - 1)/2 > 0$ and there are d_1 exceptional fibres of order a_2/d_2 and d_2 of order a_1/d_1 .
 - (c) If $d_1 = a_1$, $d_2 < a_2$, and $d < n$, then the base of the fibration is a surface of genus $g = (d_1 - 1)(d_2 - 1)/2 > 0$ and there are d_1 exceptional fibres of order a_2/d_2 and one of order n/d .
 - (d) If $d_1 = a_1$, $d_2 < a_2$, and $d = n$, then the base of the fibration is a surface of genus $g = (n + 1 - d_1 - d_2)/2 = (d_1 - 1)(d_2 - 1)/2 > 0$ and there are d_1 exceptional fibres of order a_2/d_2 .
 - (e) If $d_1 = a_1$, $d_2 = a_2$, and $d < n$, then the base of the fibration is a surface of genus $g = (d_1 - 1)(d_2 - 1)/2 > 0$ and there is one exceptional fibre of order n/d .
 - (f) If $d_1 = a_1$, $d_2 = a_2$, and $d = n$, then the base of the fibration is a surface of genus $g = (n + 1 - d_1 - d_2)/2 = (d_1 - 1)(d_2 - 1)/2 > 0$ and there are no exceptional fibres.

Let $n \geq 2$ be fixed and let M be the n -fold cyclic branched covering of some torus knot. We claim that there is a unique torus knot K such that M is homeomorphic to $M(K, n)$. Let us assume that M admits more than one Seifert fibration. Since M is a closed manifold, M is either a lens space or a prism manifold (see [Jac80, VI.16]). If M is a lens space, the base of a fibration is the 2-sphere if it is orientable,

and the fibration has at most two exceptional fibres, so the only case where lens spaces appear in the above list is case 2d for $n = 2$. This means that M must be a 2-fold branched cover and K a 2-bridge knot. Since it was shown by Hodgson and Rubinstein [HR85] that 2-bridge knots are determined by their 2-fold branched covers, we can ignore this case. If M is a prism manifold it has a single fibration with orientable base as those of our list, for the other fibration has the projective plane as base. We can thus assume that M is not a lens space and has a unique fibration among those given in the above list.

Assume first that the base of the fibration is the sphere. If there are three different types of exceptional fibres then we are either in situation 1 or in situation 2a. If there are exactly three exceptional fibres we are in situation 1 and if there are strictly more than three we are in situation 2a. In both cases, since n is fixed, it is possible to recover the invariants of the torus knot from the orders of the exceptional fibres. If there are two different types of exceptional fibres we are in cases 2b or 2c. These two cases can be distinguished by the fact that in 2b the orders of the exceptional fibres are both coprime with n , while in 2c one of them is not. Once again, in both cases, a_1 and a_2 can be retrieved from the Seifert invariants. Finally, if there is only one type of exceptional fibre, we are in case 2d and again it is possible to reconstruct a_1 and a_2 from the number of exceptional fibres and their order.

Assume now that the base of the fibration is an orientable surface of genus > 0 . If there are three types of exceptional fibres we are in case 3a, if there are two in cases 3b or 3c, if there is one in cases 3d or 3e, and if there is none we are in case 3f. In case 3c there is just one exceptional fibre of one of the two types while in case 3d there is more than one exceptional fibre of both types. A similar argument allows to distinguish cases 3d and 3e. What may be not completely obvious in this situation is how to recover $a_1 = d_1$ and $a_2 = d_2$ in cases 3e and 3f. Let us assume we are in case 3e. Since we know n , the order s of the exceptional fibre allows to compute $d_1 d_2 = d = n/s$, while the genus allows to compute $d_1 + d_2 = d_1 d_2 + 1 - 2g = n/s + 1 - 2g$ which is enough to obtain the values of $a_1 = d_1$ and $a_2 = d_2$. Case 3f is similar, keeping in mind that now $d_1 d_2 = d = n$. This completes the proof of the Proposition 4.2. \square

Acknowledgements

The contents of this work were inspired by J. Greene's paper on double branched covers of prime alternating knots. They heavily rely on the existence of a periodic minimal diagram for a prime alternating knot. In her quest for a proof of this fact, the author pestered several colleagues: M. Boileau, A. Costa, J. Greene, C. V. Quach Hongler, M. Thistlethwaite, A. Tsvietkova, J. Weeks, and possibly others she may have forgotten along the way. She wishes to express them all her deep gratitude for their patience and comments. She is also indebted to L. Watson for drawing her attention to the peculiarities of alternating diagrams of the trivial knot and B. Owens for pointing out an imprecision in the first version of the paper. Finally, the author would like to thank the anonymous referees for their thorough reading of her paper and for suggesting several improvements and even alternative proofs.

BIBLIOGRAPHY

- [Ban30] Carl Bankwitz, *Über die Torsionszahlen der alternierenden Knoten*, Math. Ann. **103** (1930), 145–161. ↑816
- [BLP05] Michel Boileau, Bernhard Leeb, and Joan Porti, *Geometrization of 3-dimensional orbifolds*, Ann. Math. **162** (2005), no. 1, 195–290. ↑825
- [BMP03] Michel Boileau, Sylvain Maillot, and Joan Porti, *Three-dimensional orbifolds and their geometric structures*, Panoramas et Synthèses, vol. 15, Société Mathématique de France, 2003. ↑825
- [Boy19] Keegan Boyle, *Odd order group actions on alternating knots*, <https://arxiv.org/abs/1906.04308>, 2019. ↑814
- [BP01] Michel Boileau and Joan Porti, *Geometrization of 3-orbifolds of cyclic type. With an appendix: Limit of hyperbolicity for spherical 3-orbifolds by Michael Heusener and Joan Porti*, Astérisque, vol. 272, Société Mathématique de France, 2001. ↑825
- [BP08] Michel Boileau and Luisa Paoluzzi, *On cyclic branched coverings of prime knots*, J. Topol. **1** (2008), no. 3, 557–583. ↑814
- [BZ03] Gerhard Burde and Heiner Zieschang, *Knots*, 2nd revised and extended ed., De Gruyter Studies in Mathematics, vol. 5, Walter de Gruyter, 2003. ↑822
- [CHK00] Daryl Cooper, Craig D. Hodgson, and Steven P. Kerckhoff, *Three dimensional orbifolds and cone-manifolds*, MSJ Memoirs, vol. 5, Mathematical Society of Japan, 2000. ↑825
- [Con67] John H. Conway, *An enumeration of knots and links, and some of their algebraic properties*, Computational Problems in Abstract Algebra (Proc. Conf., Oxford, 1967), Pergamon Press, 1967, pp. 329–358. ↑813
- [CQH19] Antonio F. Costa and Can V. Quach Hongler, *Periodic projections of alternating knots*, <https://arxiv.org/abs/1905.13718>, 2019. ↑814, 825
- [Cro04] Peter R. Cromwell, *Knots and links*, Cambridge University Press, 2004. ↑822
- [Dun88] William D. Dunbar, *Geometric orbifolds*, Rev. Mat. Univ. Complutense Madr. **1** (1988), no. 1-3, 67–99. ↑825
- [Gre13] Joshua E. Greene, *Lattices, graphs, and Conway mutation*, Invent. Math. **192** (2013), no. 3, 717–750. ↑813
- [Gre17] ———, *Alternating links and definite surfaces*, Duke Math. J. **166** (2017), no. 11, 2133–2151. ↑812
- [How17] Joshua A. Howie, *A characterisation of alternating knot exteriors*, Geom. Topol. **21** (2017), no. 4, 2353–2371. ↑812
- [HR85] Craig D. Hodgson and J. Hyam Rubinstein, *Involutions and isotopies of lens spaces*, Knot theory and manifolds (Vancouver, 1983) (Dale Rolfsen, ed.), Lecture Notes in Mathematics, vol. 1144, Springer, 1985, pp. 60–96. ↑825, 827
- [HTW98] Jim Hoste, Morwen B. Thistlethwaite, and Jeff Weeks, *The first 1,701,936 knots*, Math. Intell. **20** (1998), no. 4, 33–48. ↑814
- [Jac80] William Jaco, *Lectures on three-manifold topology*, Regional Conference Series in Mathematics, vol. 43, American Mathematical Society, 1980. ↑826
- [KL99] Paul Kirk and Charles Livingston, *Twisted knot polynomials: inversion, mutation and concordance*, Topology **38** (1999), no. 3, 663–671. ↑812
- [Koj86] Sadayoshi Kojima, *Determining knots by branched covers*, Low Dimensional Topology and Kleinian groups, London Mathematical Society Lecture Note Series, vol. 112, Cambridge University Press, 1986, pp. 193–207. ↑812
- [KT57] Shin’ichi Kinoshita and Hidetaka Terasaka, *On unions of knots*, Osaka J. Math. **9** (1957), 131–153. ↑813

- [MA73] José M. Montesinos-Amilibia, *Varietades de Seifert que son recubridores ciclicos ramificados de dos hojas*, Bol. Soc. Mat. Mex. **18** (1973), 1–32. ↑813
- [MB84] John Morgan and Hyman Bass, *The Smith conjecture*, Pure and Applied Mathematics, vol. 112, Academic Press Inc., 1984. ↑813
- [Men84] William W. Menasco, *Closed incompressible surfaces in alternating knot and link complements*, Topology **23** (1984), 37–44. ↑811, 824
- [Mil75] John W. Milnor, *On the 3-dimensional Brieskorn manifolds $M(p, q, r)$* , Knots, groups and 3-manifolds (Papers dedicated to the memory of R. H. Fox), Annals of Mathematics Studies, vol. 84, Princeton University Press, 1975, pp. 175–225. ↑825
- [MT93] William W. Menasco and Morwen B. Thistlethwaite, *The classification of alternating links*, Ann. Math. **138** (1993), no. 1, 113–171. ↑814
- [Mur58] Kunio Murasugi, *On the Alexander polynomial of the alternating knot*, Osaka J. Math. **10** (1958), 181–189. ↑824
- [Nak81] Yasutaka Nakanishi, *Primeness of links*, Math. Semin. Notes, Kobe Univ. **9** (1981), 415–440. ↑812, 813
- [Neu70] Walter D. Neumann, *S^1 -actions and the α -invariant of their involutions*, Ph.D. thesis, Bonn University, Germany, 1970, <http://www.math.columbia.edu/~neumann/preprints/neumann011.pdf>. ↑825
- [NRL03] Víctor Núñez and Enrique Ramírez-Losada, *The trefoil knot is as universal as it can be*, Topology Appl. **130** (2003), no. 1, 1–17. ↑825
- [Pao05a] Luisa Paoluzzi, *Hyperbolic knots and cyclic branched covers*, Publ. Mat., Barc. **49** (2005), no. 2, 257–284. ↑812, 813
- [Pao05b] ———, *Three cyclic branched covers suffice to determine hyperbolic knots*, J. Knot Theory Ramifications **14** (2005), no. 5, 641–655. ↑825
- [Rol76] Dale Rolfsen, *Knots and links*, Mathematical Lecture Series, vol. 7, Publish or Perish Inc., 1976. ↑812
- [Sak81] Makoto Sakuma, *Periods of composite links*, Math. Semin. Notes, Kobe Univ. **9** (1981), 445–452. ↑812, 813
- [Vir72] Oleg Y. Viro, *Links, two-sheeted branching coverings and braids*, Mat. Sb., N. Ser. **87** (129) (1972), 216–228. ↑813
- [Vir76] ———, *Non-projecting isotopies and knots with homeomorphic coverings*, Zap. Nauchn. Semin. Leningr. Otd. Mat. Inst. Steklova **66** (1976), 133–147, English transl. in J. Soviet Math. ↑812
- [Zim98] Bruno Zimmermann, *On hyperbolic knots with homeomorphic cyclic branched coverings*, Math. Ann. **311** (1998), no. 4, 665–673. ↑812, 813, 825

Manuscript received on 5th August 2020,
revised on 19th November 2020,
accepted on 23rd November 2020.

Recommended by Editor V. Colin.
Published under license CC BY 4.0.



This journal is a member of Centre Mersenne.



Luisa PAOLUZZI
Aix-Marseille Univ, CNRS, Centrale Marseille, I2M,
UMR 7373, 13453 Marseille, (France)
luisa.paoluzzi@univ-amu.fr