

## ON THE STABILIZABILITY OF HOMOGENEOUS SYSTEMS OF ODD DEGREE

HAMADI JERBI<sup>1</sup>

**Abstract.** We construct explicitly an homogeneous feedback for a class of single input, two dimensional and homogeneous systems.

**Mathematics Subject Classification.** 93D05, 93D15.

Received January 15, 2001. Revised February 19, 2002.

### 1. INTRODUCTION

Asymptotic stabilization of low dimensional non generic nonlinear systems is of much interest in nonlinear control theory since such systems occur naturally as the system evolving on a center manifold (see [1,3], etc.). Within this class, those systems with non vanishing quadratic part are generic, and there in lies our principle interest in the asymptotic stabilization problem for homogeneous systems. It has been established that in a system of ordinary differential equations if the leading homogeneous part is asymptotically stable, then the overall system is locally asymptotically stable (see [6], and [7] in the weighted homogeneous case).

In this paper we address such a problem for systems of the form

$$[\dot{x}, \dot{y}]^T = P(x, y) + uQ(x, y) \quad (1.1)$$

where  $(x, y) \in \mathbb{R}^2$ ,  $u \in \mathbb{R}$ ,  $P(x, y) = (P_1(x, y), P_2(x, y))^T$  (the notation  $M^T$  stands for the transpose matrix of  $M$ );  $P_1$  and  $P_2$  being homogeneous polynomials of degree  $2k + 1$  (i.e.  $P(\lambda x, \lambda y) = \lambda^{2k+1}P(x, y) \quad \forall \lambda \in \mathbb{R}$ )  $Q(x, y) = (Q_1(x, y), Q_2(x, y))^T$ ;  $Q_1$  and  $Q_2$  are homogeneous polynomials of degree  $p$ . Here, we wish to find a feedback function  $(x, y) \mapsto u(x, y)$ , which is homogeneous of degree  $2k + 1 - p$  and which asymptotically stabilizes the control system (1.0). If such a feedback exists, we will say that system (1.0) is globally asymptotically stabilizable (GAS). If there exists control law  $u$  such that  $\lim_{t \rightarrow \infty} (x(t), y(t)) = 0$  ( $(x(t), y(t))$  denoting the solution of  $[\dot{x}, \dot{y}]^T = P(x, y) + u(\cdot)Q(x, y)$ ,  $(x(0), y(0)) = (x_0, y_0)$ ) for all  $(x_0, y_0) \in \mathbb{R}^2$ , we will say that system (1.0) is asymptotically controllable to the origin. Obviously, to be asymptotically controllable to the origin is a necessary condition for the asymptotic stabilizability.

We give a necessary and sufficient conditions, algebraically computable, for the global asymptotic stabilization of (1.0) when  $Q_1$  and  $Q_2$  have no linear common factors and the equation  $\mathcal{G}(x, 1) = Q_1(x, 1) - Q_2(x, 1)x = 0$  has at most two solutions.

Our study generalizes the stabilizability of a large class of bilinear systems in  $\mathbb{R}^2$  considered in [4].

Our analysis here is built upon some of the recent work on the stabilizability of low dimensional systems. In particular, some topologic conditions for stabilizability which were derived by Brockett (see [2]), and later

---

*Keywords and phrases.* Asymptotic stabilization, nonlinear systems, homogeneous systems, stabilizability.

<sup>1</sup> Department of Mathematics, Sfax University, Faculty of Sciences, Tunisia; e-mail: hjerbi@voila.fr

extended by using a well known index theorem due to Krosnosel'skii and Zabreiko (see [8]) by Coron (see [5]). In this paper we will use as our principal tools some necessary conditions (Ths. 2, 3, 4 and Prop. 1) for the stabilizability of homogeneous systems.

We recall the following theorem, which will be used to prove the stabilizability of some classes of planar homogeneous systems:

**Theorem 1** (For the proof see [6]). *Consider the two dimensional system*

$$T[\dot{z}_1, \dot{z}_2] = T[f_1(z_1, z_2), f_2(z_1, z_2)]$$

where  $T[f_1, f_2]$  is Lipschitz continuous and is homogeneous of degree  $p$ . We define the function  $\mathcal{F}$

$$\mathcal{F}(x, y) = yf_1(x, y) - xf_2(x, y).$$

The system is asymptotically stable if and only if one of the following is satisfied

(i) the system does not have any one dimensional invariant subspaces and

$$I = \int_0^{2\pi} \frac{\cos \theta f_1(\cos \theta, \sin \theta) + \sin \theta f_2(\cos \theta, \sin \theta)}{\cos \theta f_2(\cos \theta, \sin \theta) - \sin \theta f_1(\cos \theta, \sin \theta)} d\theta < 0$$

or

(ii) the restriction of the system to each of its one dimensional invariant subspaces is asymptotically stable, i.e.

If the point  $(\xi_1, \xi_2)$  satisfies  $\mathcal{F}(\xi_1, \xi_2) = 0$  then  $\langle (f_1(\xi_1, \xi_2), f_2(\xi_1, \xi_2)) | (\xi_1, \xi_2) \rangle < 0$ .

In the remainder of the paper, we use essentially part (ii) of Theorem 1 to verify the stability of the closed loop system under consideration.

## 2. ASYMPTOTIC STABILIZATION OF HOMOGENEOUS SYSTEM

We consider the system

$$\begin{cases} \dot{x} = P_1(x, y) + uQ_1(x, y) \\ \dot{y} = P_2(x, y) + uQ_2(x, y) \end{cases} \tag{2.1}$$

where  $P_1$  and  $P_2$  (respectively  $Q_1$  and  $Q_2$ ) are two homogeneous polynomials of degree  $2k + 1$  (respectively  $p$ ). We define the following real functions, which will play an important role in our study

$$\Phi(x, y) = \det \begin{pmatrix} P_1(x, y) & x \\ P_2(x, y) & y \end{pmatrix} = yP_1(x, y) - xP_2(x, y)$$

$$F(x, y) = \det \begin{pmatrix} P_1(x, y) & Q_1(x, y) \\ P_2(x, y) & Q_2(x, y) \end{pmatrix} = P_1(x, y)Q_2(x, y) - P_2(x, y)Q_1(x, y)$$

$$\mathcal{G}(x, y) = \det \begin{pmatrix} Q_1(x, y) & x \\ Q_2(x, y) & y \end{pmatrix} = yQ_1(x, y) - xQ_2(x, y).$$

In this section we give a necessary and sufficient condition for the stabilizability of the homogeneous system (2.1), when the equation  $\mathcal{G}(x, 1) = Q_1(x, 1) - Q_2(x, 1)x = 0$  has at most two distinct solutions and  $Q_1$  and  $Q_2$  have no linear common factors.

The closed loop system (2.1) with the homogeneous feedback  $u(x, y)$  of degree  $(2k + 1 - p)$  is

$$\begin{cases} \dot{x} = P_1(x, y) + u(x, y)Q_1(x, y) = X_1(x, y) \\ \dot{y} = P_2(x, y) + u(x, y)Q_2(x, y) = X_2(x, y). \end{cases}$$

Letting  $\mathcal{F}(x, y) = yX_1(x, y) - xX_2(x, y)$ , it is easy to see that  $\mathcal{F}$  is an homogeneous polynomial of degree  $2k + 2$ . To prove that the feedback  $u(x, y)$  stabilizes the system (2.1), it is important to establish the following:

**Proposition 1.** *If  $\mathcal{F}(m, 1) = 0$  then the straight line  $\mathcal{D} : my - x = 0$  is invariant for the system  $\dot{x} = X_1(x, y)$ ,  $\dot{y} = X_2(x, y)$  and we have  $\langle (m, 1) | (X_1(m, 1), X_2(m, 1)) \rangle = -\frac{F(m, 1)}{\mathcal{G}(m, 1)}(1 + m^2)$ .*

*Proof.* If  $(m, 1)$  is such that  $\mathcal{F}(m, 1) = 0$  then there exists  $\nu \in \mathbb{R}$  such that

$$(X_1(m, 1), X_2(m, 1)) = (\nu m, \nu).$$

It follows that:

$$\begin{pmatrix} P_1(m, 1) & Q_1(m, 1) \\ P_2(m, 1) & Q_2(m, 1) \end{pmatrix} \begin{pmatrix} 1 \\ u(m, 1) \end{pmatrix} = \nu \begin{pmatrix} m \\ 1 \end{pmatrix}.$$

Then one can write:

$$\begin{pmatrix} 1 \\ u(m, 1) \end{pmatrix} = \frac{\nu}{F(m, 1)} \begin{pmatrix} Q_2(m, 1) & -Q_1(m, 1) \\ -P_2(m, 1) & P_1(m, 1) \end{pmatrix} \begin{pmatrix} m \\ 1 \end{pmatrix},$$

so

$$1 = -\nu \frac{\mathcal{G}(m, 1)}{F(m, 1)} \text{ and } \nu = -\frac{F(m, 1)}{\mathcal{G}(m, 1)}.$$

**Proposition 2.** *We define  $v = \rho(\cos \theta, \sin \theta)$  and  $\tilde{v} = \tilde{\rho}(\cos \tilde{\theta}, \sin \tilde{\theta})$  two vectors of  $\mathbb{R}^2$ . We suppose that  $\rho > 0$  and  $\tilde{\rho} > 0$ .*

*If  $\det(v, \tilde{v}) < 0$  then  $\widehat{\text{angle}(v, \tilde{v})} = \tilde{\theta} - \theta \in ]\pi, 2\pi[$ .*

*If  $\det(v, \tilde{v}) > 0$  then  $\widehat{\text{angle}(v, \tilde{v})} = \tilde{\theta} - \theta \in ]0, \pi[$ .*

*Proof.* The proof is rather simple and follows from

$$\det(v, \tilde{v}) = \det \begin{pmatrix} \rho \cos \theta & \tilde{\rho} \cos \tilde{\theta} \\ \rho \sin \theta & \tilde{\rho} \sin \tilde{\theta} \end{pmatrix} = \tilde{\rho} \rho \sin(\tilde{\theta} - \theta).$$

Under the assumption that the equation  $\mathcal{G}(x, 1) = 0$  has at most two distinct solutions, we can assume that  $\mathcal{G}$  takes one of these forms

- (i)  $\mathcal{G}(x, y) = (x - c_1y)(x - c_2y)f(x, y)$ , where  $f(x, y)$  is a definite homogeneous function (*i.e.*  $f(x, y) \neq 0$  for all  $(x, y) \in \mathbb{R}^2 \setminus \{(0, 0)\}$ );
- (ii)  $\mathcal{G}(x, y) = (x - cy)f(x, y)$ , where  $f(x, y)$  is a definite homogeneous function;
- (iii)  $\mathcal{G}(x, y) = \prod_i \tilde{Q}_i(x, y)$ , where  $\tilde{Q}_i$  are a definite quadratics forms.

### 2.1. Case where $\mathcal{G}(x, y) = (x - c_1y)(x - c_2y) f(x, y)$

We consider the equation

$$\begin{cases} \dot{x} = Q_1(x, y) \\ \dot{y} = Q_2(x, y) \end{cases} \tag{2.2}$$

where  $Q_1$  and  $Q_2$  are two homogeneous polynomials of degree  $p$ . We recall the function  $\mathcal{G}$

$$\mathcal{G}(x, y) = (x - c_1y)(x - c_2y)f(x, y)$$

with  $f(x, y) \neq 0$  for all  $(x, y) \in \mathbb{R}^2 \setminus \{(0, 0)\}$ . Without loss of generality, one can suppose that the function  $f$  is definite negative (*i.e.*  $f(x, y) < 0 \forall (x, y) \in \mathbb{R}^2 \setminus \{(0, 0)\}$ ). In these conditions, one necessarily has  $p = 2q + 1$ .

We define  $\lambda = Q_2(c_1, 1)$ ,  $\rho = Q_2(c_2, 1)$ . The representation of system  $\dot{x} = Q_1(x, y)$ ,  $\dot{y} = Q_2(x, y)$  in polar coordinates is

$$\begin{aligned} \dot{r} &= r^p (\cos \theta Q_1(\cos \theta, \sin \theta) + \sin \theta Q_2(\cos \theta, \sin \theta)) = r^p g(\theta) \\ \dot{\theta} &= r^{p-1} (\cos \theta Q_2(\cos \theta, \sin \theta) - \sin \theta Q_1(\cos \theta, \sin \theta)) = -r^{p-1} \mathcal{G}(\cos \theta, \sin \theta). \end{aligned}$$

If we introduce a new time  $s$  via  $\frac{ds}{dt} = r^{p-1}$  then the above system becomes

$$\dot{r} = r g(\theta) \quad \hat{E} \dot{\theta} = -\mathcal{G}(\cos \theta, \sin \theta).$$

According to [6] one can see that the straight lines  $\mathcal{D}_1: x + c_1 y = 0$  and  $\mathcal{D}_2: x + c_2 y = 0$  are invariant for (2.2) and the orbits of the equation (2.2) take one of the following forms:

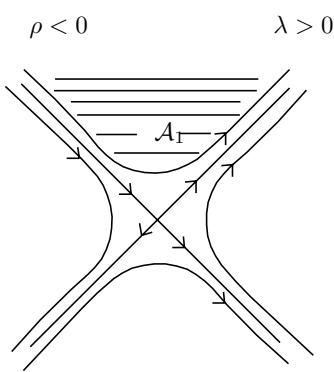

FIGURE 1.  $\mathbb{R}^2 \setminus \{(0, 0) \cup \mathcal{O}_{(x_0, y_0)}\} = \mathcal{A}_1 \cup \bar{\mathcal{A}}_1$   $\mathcal{A}_1$  and  $\bar{\mathcal{A}}_1$  are two connected sets.

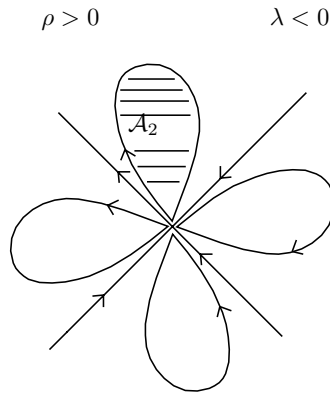

FIGURE 2.  $\mathbb{R}^2 \setminus \{(0, 0) \cup \mathcal{O}_{(x_0, y_0)}\} = \mathcal{A}_2 \cup \bar{\mathcal{A}}_2$   $\mathcal{A}_2$  and  $\bar{\mathcal{A}}_2$  are two connected sets.

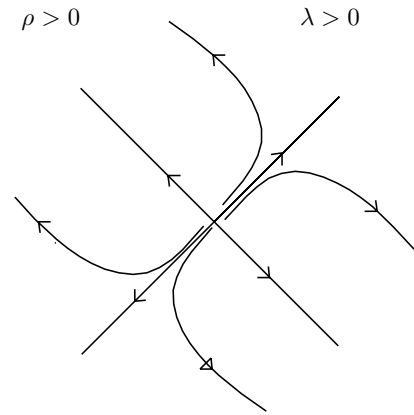

FIGURE 3. We have the same figure when  $\lambda < 0$  and  $\rho < 0$ .

For the stabilizability of system (2.1), we need some results guaranteeing the existence of the homogeneous feedback. Let us define  $\alpha = \Phi(c_1, 1)$ ,  $\beta = \Phi(c_2, 1)$ .

With this notation, one can easily verify that:

$$F(c_1, 1) = Q_2(c_1, 1)\Phi(c_1, 1) = \lambda\alpha \text{ and } F(c_2, 1) = Q_2(c_2, 1)\Phi(c_2, 1) = \rho\beta.$$

**Theorem 2.** *If  $\alpha\beta < 0$  and the system (2.1) is GAS then there exists some  $m \in ]c_1, c_2[$  such that  $F(m, 1) > 0$ .*

*Proof.* It is easy to see that if  $\lambda > 0$  and  $\rho > 0$  (respectively  $\lambda < 0$  and  $\rho < 0$ ) then  $F(c_1, 1)F(c_2, 1) = \rho\lambda\alpha\beta < 0$  and there exists an  $m \in ]c_1, c_2[$  such that  $F(m, 1) > 0$ .

In the case where  $\lambda > 0$  and  $\rho < 0$ , for all  $m \in ]c_1, c_2[$  we have  $F(m, 1) < 0$ . Since  $F(m, 1) = \det \begin{pmatrix} P_1(m, 1) & Q_1(m, 1) \\ P_2(m, 1) & Q_2(m, 1) \end{pmatrix} < 0$ , and according to Proposition 2 we can deduce that  $\text{angle}(\widehat{P, Q}) \in ]\pi, 2\pi[$  and it follows that the subset  $\mathcal{A}_1$  is invariant for the open loop system (2.1) (see Fig. 1). So it cannot be asymptotically controllable to the origin.

In the case where  $\lambda < 0$  and  $\rho > 0$ , for all  $m \in ]c_1, c_2[$  we have  $F(m, 1) < 0$ . Since  $F(m, 1) = \det \begin{pmatrix} P_1(m, 1) & Q_1(m, 1) \\ P_2(m, 1) & Q_2(m, 1) \end{pmatrix} < 0$ , and according to Proposition 2 we can deduce that  $\text{angle}(\widehat{P, Q}) \in ]\pi, 2\pi[$  and it follows that the subset  $\mathcal{A}_2$  is invariant for the open loop system (2.1) (see Fig. 2). Using the fact that if any equation  $\dot{p} = Y(p)$  is GAS on the manifold  $\mathcal{M}$  then  $\mathcal{M}$  must be simply connected. We can assume that system (2.1) cannot be GAS.

**Theorem 3.** *If  $\alpha = 0$ ,  $\frac{\rho\beta}{c_1 - c_2} < 0$  and the system (2.1) is GAS then there exists some  $m \in ]c_1, c_2[$  such that  $F(m, 1) > 0$ .*

*Proof.* Clearly if  $\lambda > 0$  and  $\rho > 0$  (respectively  $\lambda < 0$  and  $\rho < 0$ ) then  $F(c_1, 1)F(c_2, 1) = \rho\lambda\alpha\beta < 0$  and there exists some  $m \in ]c_1, c_2[$  such that  $F(m, 1) > 0$ .

In the case where  $\lambda > 0$  and  $\rho < 0$  (respectively  $\lambda < 0$  and  $\rho > 0$ ), for all  $m \in ]c_1, c_2[$  we have  $F(m, 1) < 0$ . Since  $F(m, 1) = \det \begin{pmatrix} P_1(m, 1) & Q_1(m, 1) \\ P_2(m, 1) & Q_2(m, 1) \end{pmatrix} < 0$ , then the subset  $\mathcal{A}_1$  (respectively  $\mathcal{A}_2$ ) is invariant for the open loop system (2.1) (see Figs. 1, 2). So it cannot be asymptotically controllable (respectively stabilizable) to origin.

We can also prove the following theorem:

**Theorem 4.** *If  $\alpha = \beta = 0$ ,  $\rho\lambda < 0$  and the system (2.1) is GAS then there exists some  $m \in ]c_1, c_2[$  such that  $F(m, 1) > 0$ .*

We consider an homogeneous feedback  $u(x, y)$  of degree  $2k + 1 - p$  which makes the system (2.1) globally asymptotically stable. We denote  $X_1(x, y) = P_1(x, y) + u(x, y)Q_1(x, y)$  and  $X_2(x, y) = P_2(x, y) + u(x, y)Q_2(x, y)$ . It is clear that  $X_1, X_2$  are homogeneous polynomials of degree  $2k + 1$ . Let  $\mathcal{F}(x, y) = yX_1(x, y) - xX_2(x, y)$ , a simple computation gives

$$\mathcal{F}(x, y) = \Phi(x, y) + u(x, y)\mathcal{G}(x, y).$$

From Theorem 1 the function  $\mathcal{F}$  play an important role in the stabilizability of the vector field  $(X_1, X_2)$ . Moreover to determine the feedback  $u(x, y)$  which stabilizes system (2.1) we must choose the function  $\mathcal{F}$  such that

- ( $\Gamma_1$ ) the functions  $(x - c_i y)$  divide the homogeneous function  $\mathcal{F}(x, y) - \Phi(x, y)$  for  $i \in \{1, 2\}$ ;
- ( $\Gamma_2$ ) if the point  $(m, 1)$  is such that  $\mathcal{F}(m, 1) = 0$  then  $\langle (X_1(m, 1), X_2(m, 1)) \mid (m, 1) \rangle < 0$ ;
- ( $\Gamma_3$ ) the function  $\mathcal{F}(x, y)$  must be an homogeneous function of degree  $2k + 2$ .

Here it is important to show that from Proposition 1, the condition ( $\Gamma_2$ ) is equivalent to

If the point  $(m, 1)$  satisfy  $\mathcal{F}(m, 1) = 0$  then  $\frac{F(m, 1)}{\mathcal{G}(m, 1)} > 0$ .

Theorems 2, 3, and 4 guarantee the existence of the set of points  $M_i : (m_i, 1)$  such that  $\frac{F(m_i, 1)}{\mathcal{G}(m_i, 1)} > 0$ .

**Theorem 5.** *If there exists a function  $\mathcal{F}(x, y)$  satisfying the conditions ( $\Gamma_1$ ), ( $\Gamma_2$ ) and ( $\Gamma_3$ ) then the feedback*

$$u(x, y) = \frac{\mathcal{F}(x, y) - \Phi(x, y)}{\mathcal{G}(x, y)}$$

*is  $\mathcal{C}^\infty$  on  $\mathbb{R}^2 \setminus \{0\}$ , homogeneous of degree  $2k + 1 - p$  and stabilizes the system (2.1).*

*Proof.* Since the function  $\mathcal{F}$  satisfies ( $\Gamma_1$ ), we can establish

$$\mathcal{F}(x, y) - \Phi(x, y) = (x - c_1 y)(x - c_2 y)\tilde{\mathcal{F}}(x, y),$$

this implies

$$u(x, y) = \frac{\mathcal{F}(x, y) - \Phi(x, y)}{\mathcal{G}(x, y)} = \frac{\tilde{\mathcal{F}}(x, y)}{f(x, y)}$$

which is  $\mathcal{C}^\infty$  on  $\mathbb{R}^2 \setminus \{0\}$  and homogeneous of degree  $2k + 1 - p$ . The proof of the theorem follows from the fact that the closed loop system with the feedback  $u(x, y)$  is homogeneous of degree  $2k + 1$  and it satisfies to the condition (ii) of Theorem 1.

**Theorem 6.** *If  $\lambda\rho > 0$  then for  $\eta > 0$  large enough, the feedback*

$$u(x, y) = -\eta\lambda(x^2 + y^2)^{k-q}$$

*stabilizes the system (2.1).*

*Proof.* The proof is rather simple and requires only to show that the vector fields  $-\lambda(x^2 + y^2)^{k-p}Q(x, y)$  is GAS and using the same argument as in the proof of Theorem 5 one can deduce that for  $\eta > 0$  large enough the feedback

$$u(x, y) = -\eta\lambda(x^2 + y^2)^{k-q}$$

stabilizes the system (2.1).

**Theorem 7.** *In the case when  $\lambda\rho < 0$ , the system (2.1) is GAS if and only if the following holds.*

(S) *There exist  $m_1 \in ]c_1, c_2[$  and  $m_2 \in ]-\infty, c_1[ \cup ]c_2, \infty[$  such that  $F(1, m_1) > 0$  and  $F(1, m_2) < 0$ .*

*In this case there exists an homogeneous feedback of degree  $2k - 2q$  which stabilizes the system (2.1). Stabilizing feedback control laws are given in the following table.*

case	The feedback
$\alpha\beta > 0$	$u(x, y) = \frac{\alpha(x - m_1y)^2(a(x - c_2y)^2 + b(x - c_1y)^2)^K - \Phi(x, y)}{(x - c_1y)(x - c_2y)f(x, y)}$ <p>where <math>a = \frac{1}{(c_1 - c_2)^2} \left( \frac{1}{(c_1 - m_1)^2} \right)^{1/k}</math> and <math>b = \frac{1}{(c_1 - c_2)^2} \left( \frac{\beta}{\alpha(c_2 - m_1)^2} \right)^{1/k}</math>.</p>
$\alpha\beta < 0$	$u(x, y) = \frac{\left( \frac{\alpha}{c_1 - m_2} \right) (x - m_1y)(x - m_2y)(a(x - c_2y)^2 + b(x - c_1y)^2)^k - \Phi(x, y)}{(x - c_1y)(x - c_2y)f(x, y)}$ <p>where <math>a = \frac{1}{(c_1 - c_2)^2} \left( \frac{1}{c_1 - m_1} \right)^{1/k}</math> and <math>b = \frac{1}{(c_1 - c_2)^2} \left( \frac{\beta(c_1 - m_2)}{\alpha(c_2 - m_1)(c_2 - m_2)} \right)^{1/k}</math>.</p>
$\alpha = 0; \lambda\beta > 0$	$u(x, y) = \frac{\beta(x - c_1y)(x - m_1y)(a(x - c_2y)^2 + b(x - c_1y)^2)^k - \Phi(x, y)}{(x - c_1y)(x - c_2y)f(x, y)}$ <p>where <math>b = \frac{1}{(c_2 - c_1)^2} \left( \frac{1}{(c_2 - c_1)(c_2 - m_1)} \right)^{1/k}</math> and <math>a &gt; 0</math>, large enough.</p>
$\alpha = 0; \lambda\beta < 0$	$u(x, y) = \frac{\beta(c_1 - m_2)(x - c_1y)(x - m_2y)(a(x - c_2y)^2 + b(x - c_1y)^2)^k - \Phi(x, y)}{(x - c_1y)(x - c_2y)f(x, y)}$ <p>where <math>b = \frac{1}{(c_2 - c_1)^2} \left( \frac{1}{(c_2 - c_1)(c_2 - m_2)(c_2 - c_1)} \right)^{1/k}</math> and <math>a &gt; 0</math> large enough.</p>
$\beta = 0 \alpha\rho > 0$	$u(x, y) = \frac{\alpha(x - c_2y)(x - m_1y)(a(x - c_2y)^2 + b(x - c_1y)^2)^k - \Phi(x, y)}{(x - c_1y)(x - c_2y)f(x, y)}$ <p>where <math>a = \frac{1}{(c_2 - c_1)^2} \left( \frac{1}{(c_1 - c_2)(c_1 - m_1)} \right)^{1/k}</math> and <math>b &gt; 0</math> large enough.</p>

$$\beta = 0 \ \alpha\rho < 0 \quad u(x, y) = \frac{-\alpha(c_2 - m_2)(x - c_2y)(x - m_2y) (a(x - c_2y)^2 + b(x - c_1y)^2)^k - \Phi(x, y)}{(x - c_1y)(x - c_2y)f(x, y)}$$

$$\text{where } a = \frac{1}{(c_2 - c_1)^2} \left( \frac{1}{(c_2 - c_1)(c_1 - m_2)(c_2 - m_2)} \right)^{1/k} \text{ and } b > 0 \text{ large enough.}$$

$$\beta = \alpha = 0 \quad u(x, y) = \frac{-\lambda(c_2 - m_2)(x - c_1y)(x - c_2y)(x - m_1y)(x - m_2y) (a(x - c_2y)^2 + b(x - c_1y)^2)^{(k-2)} - \Phi(x, y)}{(x - c_1y)(x - c_2y)f(x, y)}$$

where  $a > 0$  and  $b > 0$  are large enough.

*Proof.* The condition (S) follows from Theorems 2, 3 and 4. Suppose that there exist  $m_1$  and  $m_2 \in \mathbb{R}$  such that  $F(1, m_1) > 0$  and  $F(1, m_2) < 0$ . We consider the closed loop system (2.1)

$$\begin{cases} \dot{x} = P_1(x, y) + u(x, y)Q_1(x, y) = X_1(x, y) \\ \dot{y} = P_2(x, y) + u(x, y)Q_2(x, y) = X_2(x, y) \end{cases}$$

to determine the stabilizing feedback of the system (1.2), we construct an homogeneous function  $\mathcal{F}(x, y) = \det \begin{pmatrix} X_1(x, y) & x \\ X_2(x, y) & y \end{pmatrix}$  witch satisfies to the conditions  $(\Gamma_1)$ ,  $(\Gamma_2)$  and  $(\Gamma_3)$ . It is clear that  $\mathcal{F}(x, y) = \Phi(x, y) + u(x - c_1y)(x - c_2y)f(x, y)$  and

$$u(x, y) = \frac{\mathcal{F}(x, y) - \Phi(x, y)}{(x - c_1y)(x - c_2y)f(x, y)}.$$

Here we investigate some cases and all other cases can be treated similarly.

In the case when  $\alpha\beta > 0$  we choose

$$\mathcal{F}(x, y) = \alpha(x - m_1y)^2 (a(x - c_2y)^2 + b(x - c_1y)^2)^k,$$

$a = \frac{1}{(c_2 - c_1)^2} (1/(c_1 - m_1)^2)^{1/k}$  and  $b = \frac{1}{(c_2 - c_1)^2} (\frac{\beta}{\alpha(c_2 - m_1)^2})^{1/k}$ . For this choice of  $a$  and  $b$  we can assume that  $(x - c_1y)(x - c_2y)$  divides  $\mathcal{F}(x, y) - \Phi(x, y)$ , and it follows that the function  $\mathcal{F}$  satisfies to the conditions  $(\Gamma_1)$ ,  $(\Gamma_2)$  and  $(\Gamma_3)$ .

For  $\beta = \alpha = 0$  we construct

$$\mathcal{F}(x, y) = -\lambda(c_2 - m_2)(x - c_1y)(x - c_2y)(x - m_1y)(x - m_2y) (a(x - c_2y)^2 + b(x - c_1y)^2)^{(k-2)}.$$

Straightforward calculations yield that

$$X_2(c_1, 1) = P_2(c_1, 1) - \frac{(c_2 - m_2)(c_1 - c_2)(c_1 - m_1)(c_1 - m_2)(a(c_1 - c_2)^2)^k}{(c_1 - c_2)f(c_1, 1)} \lambda^2 - \frac{\Phi'_x(c_1, 1)}{(c_1 - c_2)f(c_1, 1)} \lambda$$

and

$$X_2(c_2, 1) = P_2(c_2, 1) - \frac{(c_2 - m_2)^2(c_2 - c_1)(c_2 - m_1)(b(c_1 - c_2)^2)^k}{(c_2 - c_1)f(c_2, 1)} \lambda\rho - \frac{\Phi'_x(c_2, 1)}{(c_2 - c_1)f(c_2, 1)} \rho.$$

For  $a > 0$  and  $b > 0$  large enough we obtain  $X_2(c_1, 1) < 0$  and  $X_2(c_2, 1) < 0$ .  $\mathcal{F}$  satisfies to the conditions  $(\Gamma_1)$ ,  $(\Gamma_2)$  and  $(\Gamma_3)$  hence the system (2.1) is GAS.

2.2. The case when  $\mathcal{G}(x, y) = (x - cy) f(x, y)$

Where  $f(x, y)$  is definite negative. Under these hypothesis we have necessarily  $p = 2q$ . We set  $\lambda = Q_2(c, 1)$ . According to [6] one can see that the straight line  $\mathcal{D} : x + cy = 0$  is invariant for the equation

$$\begin{cases} \dot{x} = Q_1(x, y) \\ \dot{y} = Q_2(x, y) \end{cases}$$

and the orbits of this equation take one of the following forms:

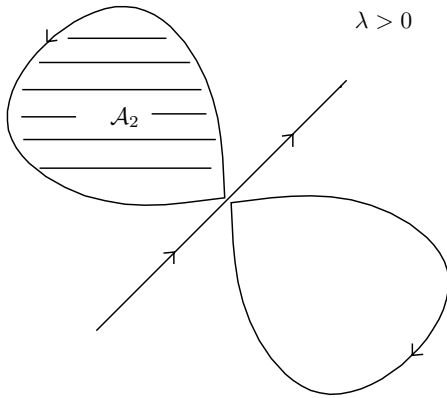

FIGURE 4.  $\mathbb{R}^2 \setminus \{(0, 0) \cup \mathcal{O}_{(x_0, y_0)}\} = \mathcal{A}_2 \cup \tilde{\mathcal{A}}_2$   $\mathcal{A}_2$  and  $\tilde{\mathcal{A}}_2$  are two connected sets.

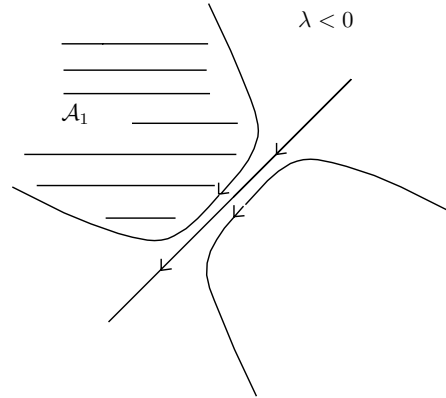

FIGURE 5.  $\mathbb{R}^2 \setminus \{(0, 0) \cup \mathcal{O}_{(x_0, y_0)}\} = \mathcal{A}_1 \cup \tilde{\mathcal{A}}_1$   $\mathcal{A}_1$  and  $\tilde{\mathcal{A}}_1$  are two connected sets.

**Theorem 8.** The system (2.1) is GAS if and only if there exists  $m \in \mathbb{R}$  such that  $(c - m)F(m, 1) > 0$  (S), and if the condition (S) holds then, in the case when  $\Phi(c, 1) = \alpha \neq 0$  the homogeneous feedback

$$u(x, y) = \frac{\alpha(x - my)^2((x - cy)^2 + by^2)^k - \Phi(x, y)}{(x - cy)f(x, y)}$$

where  $b = (c - m)^{(-2/k)}$  stabilizes the system (2.1), and in the case when  $\alpha = 0$ , one has for  $b > 0$  large enough the homogeneous feedback

$$u(x, y) = \frac{\lambda(c - m)(x - cy)(x - my)(x^2 + by^2)^k - \Phi(x, y)}{(x - cy)f(x, y)}$$

stabilizes the system (2.1).

*Proof.* The property (S) follows from Theorem 2 (with  $\rho = -\lambda$ ). Conversely, we suppose that there exists  $m \in \mathbb{R}$  such that  $(c - m)F(m, 1) > 0$ . The closed loop system (2.1) with the feedback  $u(\cdot)$  is

$$\begin{cases} \dot{x} = P_1(x, y) + u(x, y)Q_1(x, y) = X_1(x, y) \\ \dot{y} = P_2(x, y) + u(x, y)Q_2(x, y) = X_2(x, y). \end{cases}$$

In these conditions one has

$$\mathcal{F}(x, y) = \Phi(x, y) + u(x - cy)f(x, y).$$



From Theorem 1 the function  $\mathcal{F}$  plays an important role in the stabilizability of the vector field  $(X_1, X_2)$ . Moreover to prove that the feedback  $u(x, y)$  stabilizes system (2.1) the function  $\mathcal{F}$  must satisfies to the following conditions:

- ( $\Gamma'_1$ ) if the point  $(\xi, 1)$  is such that  $\mathcal{F}(\xi, 1) = 0$  then  $\langle (X_1(\xi, 1), X_2(\xi, 1)) | (\xi, 1) \rangle < 0$ ;
- ( $\Gamma'_2$ ) the function  $\mathcal{F}(x, y)$  is an homogeneous function of degree  $2k + 2$ .

Here it is important to show that from Proposition 1, the condition ( $\Gamma'_2$ ) is equivalent to

If the point  $(\xi, 1)$  verify  $\mathcal{F}(\xi, 1) = 0$  then  $\frac{F(\xi, 1)}{\mathcal{G}(\xi, 1)} > 0$ .

The condition of the stabilizability guarantee the existence of a point  $M : (m, 1)$  such that  $\frac{F(m, 1)}{\mathcal{G}(m, 1)} > 0$ .

For  $\alpha \neq 0$  we found  $\mathcal{F}(x, y) = \alpha(x - my)^2((x - cy)^2 + by^2)^k$  witch is misspelled to the conditions ( $\Gamma'_1$ ) and ( $\Gamma'_2$ ).

In the case  $\alpha = 0$  we found  $\mathcal{F}(x, y) = \lambda(c - m)(x - cy)(x - my)(ax^2 + by^2)^k$  and  $X_2(c, 1) = P_2(c, 1) - \frac{(c-m)(c^2+b)^k}{f(c,1)}\lambda^2 - \frac{\Phi'_x(c,1)}{f(c,1)}\lambda$ . For  $b > 0$  large enough, one has  $X_2(c_1, 1) < 0$  and the system (2.1) is GAS.

### 2.3. Case when $\mathcal{G}(x, y)$ is definite

Without loss of generality, one can suppose that  $\mathcal{G}(x, y)$  is a positive definite function (i.e.  $\mathcal{G}(x, y) > 0 \forall (x, y) \in \mathbb{R}^2 \setminus \{(0, 0)\}$ ), we denote

$$I = \int_{-\infty}^{+\infty} \frac{Q_1(1, s)}{\mathcal{G}(1, s)} ds.$$

If  $I \neq 0$  then the orbits of the vector fields  $Q(z) = (Q_1(z), Q_2(z))$  will be spirals. Moreover, if  $IQ_2(1, 0) > 0$  (respectively  $IQ_2(1, 0) < 0$ ) then  $-Q$  (respectively  $Q$ ) will be globally asymptotically stable (GAS).

If  $I = 0$  then the orbits of the vector fields  $Q(z) = (Q_1(z), Q_2(z))$  are periodic and  $(0, 0)$  is a center. We have  $Q_2(1, 0) = -\mathcal{G}(1, 0) < 0$ .

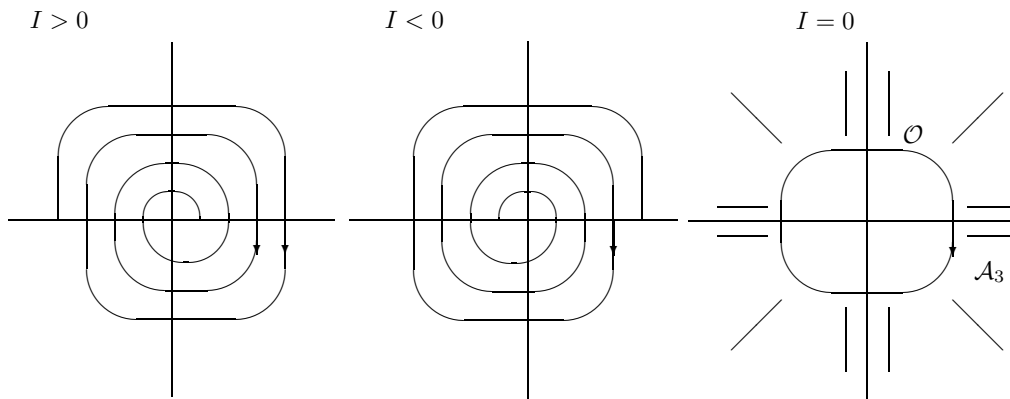

FIGURE 6

FIGURE 7

FIGURE 8

**Theorem 9.** In the case when  $I \neq 0$  one has for  $\eta > 0$  large enough the feedback

$$u(x, y) = \eta \varepsilon (x^2 + y^2)^{k-q} \quad \text{where } \varepsilon = \frac{|I|}{I}$$

stabilizes the system (2.1).

*Proof.* Since the vector fields  $\varepsilon(x^2 + y^2)^{k-q} Q(z)$  where  $\varepsilon = \frac{|I|}{I}$  are GAS and are homogeneous of degree  $2k + 1$ , then from [9] there exists  $\xi > 0$  such that for all vector fields  $h$  definite on  $\mathbb{R}^2$  and verify  $\|h(x, y)\| \leq \xi \|(x, y)\|^{2k+1}$ , one has that  $\varepsilon(x^2 + y^2)^{k-q} Q(z) + h(z)$  is locally asymptotically stable.

The function  $P(x, y)$  is homogeneous of degree  $2k + 1$ , so  $\|P(x, y)\| \leq A\|(x, y)\|^{2k+1}$  where

$$A = \sup_{(x,y) \in S^1} \|P(x, y)\|.$$

It is clear that for  $\eta > 0$  large enough the vector fields  $P(z) + \eta\varepsilon(x^2 + y^2)^{k-q} Q(z)$  are locally asymptotically stable, and since it is homogeneous then the vector fields is GAS.

**Theorem 10.** *In the case when  $I = 0$  one has:*

*The system (2.1) is GAS if and only if it holds the following properties (S)*

*(S) there exists some  $m$  such that  $F(1, m) > 0$ .*

*In this case the homogeneous feedback*

$$u(x, y) = \frac{(x - my)^2(x^{2k} + y^{2k}) - \Phi(x, y)}{\mathcal{G}(x, y)}$$

*stabilizes the system (2.1).*

*Proof.* We define  $z(t)$  the solution of the equation  $\dot{z}(t) = Q(z(t))$ ,  $z(0) = (1, 1)$ . Let  $\mathcal{O} = \{z(t) \ \forall t \in \mathbb{R}\}$ . It is clear that  $\mathbb{R}^2 - \{\mathcal{O}\} = \mathcal{A}_3 \cup \tilde{\mathcal{A}}_3$  where  $\mathcal{A}_3$  and  $\tilde{\mathcal{A}}_3$  are two connected open sets. Without loss of generality, let  $(0, 0) \in \tilde{\mathcal{A}}_3$ .

If the system holds the condition (S) then for all  $x, y \in \mathbb{R}$

$$\Phi(x, y) = \det \begin{pmatrix} P_1(x, y) & Q_1(x, y) \\ P_2(x, y) & Q_2(x, y) \end{pmatrix} < 0$$

it follows that the angle  $(P(z(t)), Q(z(t)))$  lie in  $]\pi, 2\pi[$  and for such control  $u(\cdot)$  the subset  $\mathcal{A}_3$  is invariant for the system  $\dot{z} = P + uQ$  (see Fig. 8). The system (2.1) is not asymptotically controllable to the origin hence it can not be stabilizable.

Conversely, suppose that there exists some  $m$  such that  $F(1, m) > 0$ . We define  $u(x, y) = \frac{(x - cy)^2(x^{2k} + y^{2k}) - \Phi(x, y)}{\mathcal{G}(x, y)}$  and the system  $\dot{z} = P(z) + u(z)Q(z) = Y(z)$ . If  $\mathcal{F}(x, y) = yY_1(x, y) - xY_2(x, y)$  straightforward

$$\mathcal{F}(x, y) = (x - my)^2 (x^{2k} + y^{2k}).$$

From Theorem 1 and Proposition 1, the vector fields  $Y(z)$  are GAS.

## REFERENCES

- [1] D. Ayels, Stabilization of a class of nonlinear systems by a smooth feedback. *System Control Lett.* **5** (1985) 181-191.
- [2] R.W. Brockett, *Differential Geometric Control Theory*, Chapter Asymptotic stability and feedback stabilization. Brockett, Milmann, Sussman (1983) 181-191.
- [3] J. Carr, *Applications of Center Manifold Theory*. Springer Verlag, New York (1981).
- [4] R. Chabour, G. Sallet and J.C. Vivalda, Stabilization of nonlinear two dimensional system: A bilinear approach. *Math. Control Signals Systems* (1996) 224-246.
- [5] J.M. Coron, A Necessary Condition for Feedback Stabilization. *System Control Lett.* **14** (1990) 227-232.
- [6] W. Hahn, *Stability of Motion*. Springer Verlag (1967).
- [7] H. Hermes, *Homogeneous Coordinates and Continuous Asymptotically Stabilizing Control laws*, Differential Equations, Stability and Control, edited by S. Elaydi. Marcel Dekker Inc., *Lecture Notes in Appl. Math.* **10** (1991) 249-260.
- [8] M.A. Krasnosel'skii and P.P. Zabreiko *Geometric Methods of Nonlinear Analysis*. Springer Verlag, New York (1984).
- [9] J.L. Massera, Contribution to stability theory. *Ann. Math.* **64** (1956) 182-206.